

Description

Silicon NPN transistor in a SOT-23 Plastic Package

Applications

Audio frequency general amplifier application

Features

- High h_{FE} and V_{CE0}
- Complementary pair with 2SA812
- Halogen-free Product

Symbol	Parameter	Max	Unit
V_{CE0}	collector-emitter voltage	50	V
I_c	collector current (DC)	100	mA

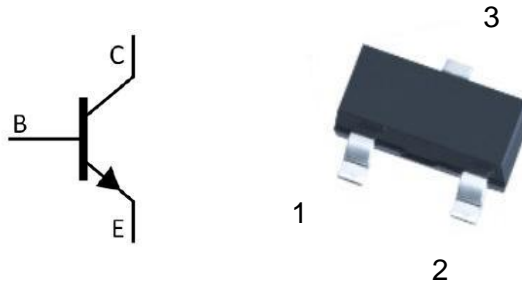
Equivalent Circuit & Pinning

PIN1: Base

PIN 2: Emitter

PIN 3: Collector

 h_{FE} Classifications & Marking

h_{FE} Classifications Symbol	O	Y	G	L
h_{FE} Range	90~180	135~270	200~400	300~600
Marking	HL4	HL5	HL6	HL7

Absolute Maximum Ratings(Ta=25°C)

Parameter	Symbol	Rating	Unit
Collector to Base Voltage	V_{CB0}	60	V
Collector to Emitter Voltage	V_{CEO}	50	V
Emitter to Base Voltage	V_{EBO}	5.0	V
Collector Current	I_C	100	mA
Collector Power Dissipation	P_C	200	mW
Junction Temperature	T_j	150	°C
Storage Temperature Range	T_{stg}	-55~150	°C

Electrical Characteristics(Ta=25°C)

Parameter	Symbol	Test Conditions	Min	Typ	Max	Unit
Collector Cut-Off Current	I_{CB0}	$V_{CB}=60V$ $I_E=0$			0.1	μA
Emitter Base Cut-Off Current	I_{EBO}	$V_{EB}=5.0V$ $I_C=0$			0.1	μA
DC Current Gain	h_{FE}	$V_{CE}=6.0V$ $I_C=1.0mA$	90	200	600	
Collector to Emitter Saturation Voltage	$V_{CE(sat)}$	$I_C=100mA$ $I_B=10mA$		0.15	0.3	V
Base to Saturation Voltage	$V_{BE(sat)}$	$I_C=100mA$ $I_B=10mA$		0.86	1.0	V
Base Emitter Voltage	V_{BE}	$V_{CE}=6.0V$ $I_C=1.0mA$	0.55	0.62	0.65	V
Transition Frequency	f_T	$V_{CE}=6.0V$ $I_E=10mA$		250		MHz
Collector Output Capacitance	C_{ob}	$V_{CB}=6.0V$ $f=1.0MHz$ $I_E=0$		3.0		pF

Electrical Characteristic Curve

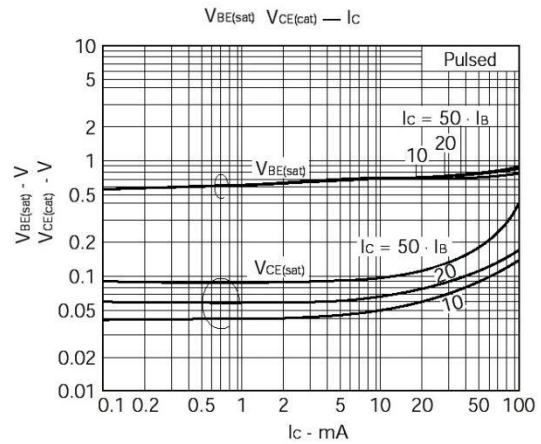
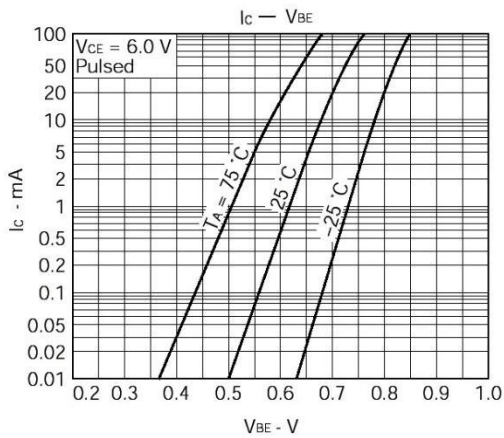
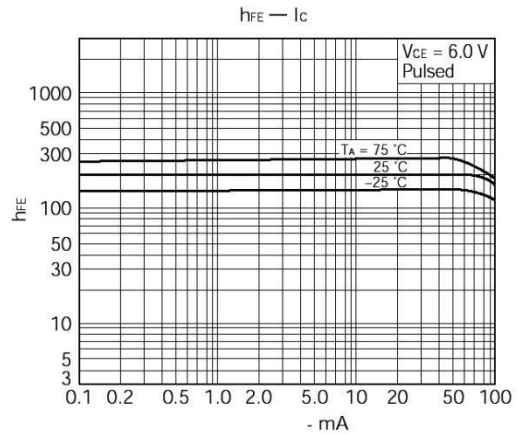
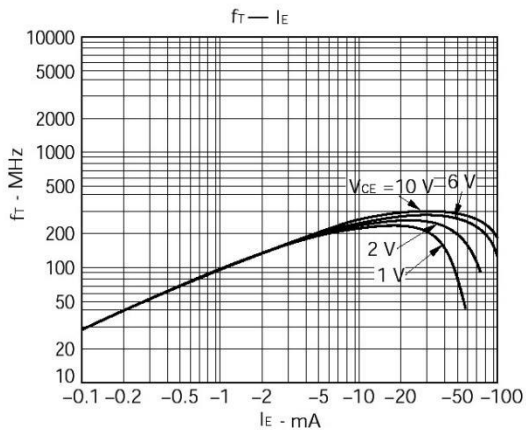
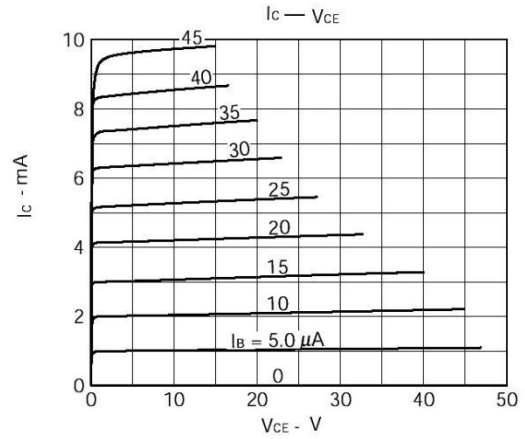
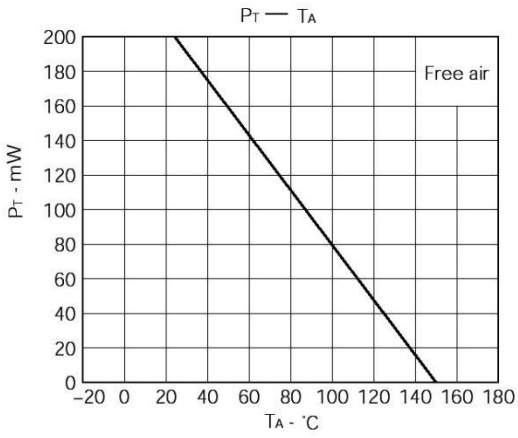

Marking Instructions

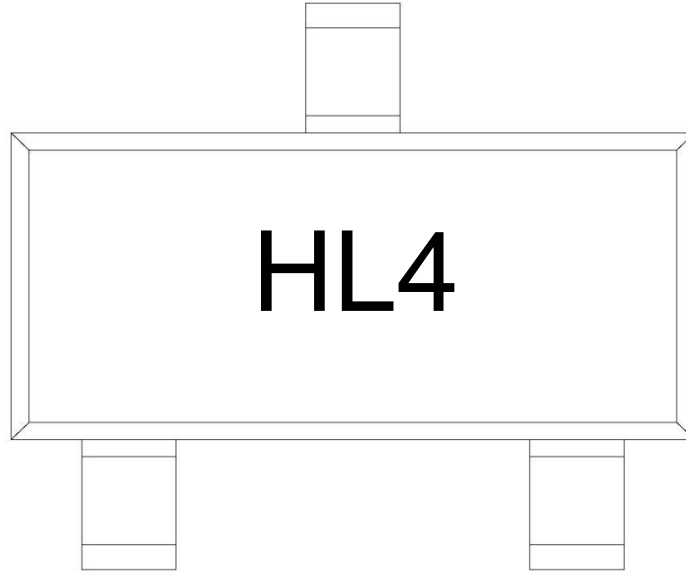

Note:

- H: Company Code
- L4: Product Type Code

h _{FE} Classifications Symbol	O	Y	G	L
h _{FE} Range	90~180	135~270	200~400	300~600
Marking	HL4	HL5	HL6	HL7

Packaging SPEC.

REEL INFORMATION

Package Type	Units					Dimension (unit: mm ³)		
	Units/Reel	Reels/Inner Box	Units/Inner Box	Inner Boxes/Outer Box	Units/Outer Box	Reel	Inner Box	Outer Box
SOT-23	3,000	10	30,000	6	180,000	7" x8	180x120x180	390x385x205

Package Outline Dimensions

SOT-23

单位: mm

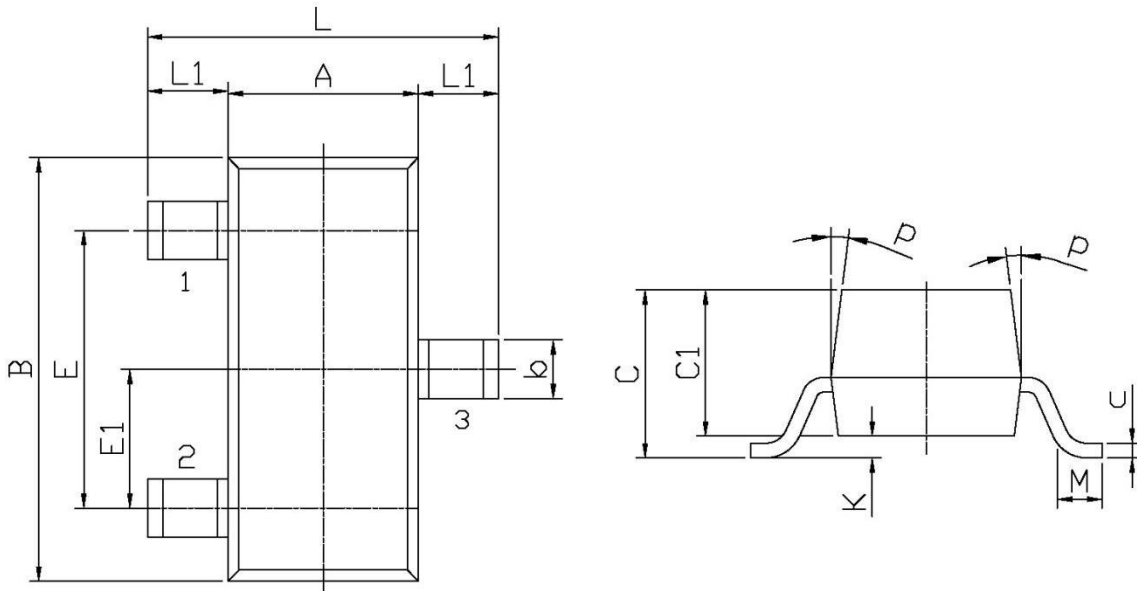

Symbol	Dimensions In Millimeters		Symbol	Dimensions In Millimeters	
	Min	Max		Min	Max
L	2.2	2.7	C	1.30Max	
L1	0.45	0.65	C1	0.90	1.20
A	1.15	1.50	c	0.05	0.20
B	2.70	3.10	K	0	0.10
E	1.70	2.10	M	0.20MIN	
E1	0.85	1.05	P	7°	
b	0.35	0.55			