

Description

Silicon PNP transistor in a SOT-23 Plastic Package

Applications

General purpose amplifier and switching.

Features

- High DC Current Gain
- Low Collector to Emitter Saturation Voltage
- Halogen-free Product

Symbol	Parameter	Max	Unit
V_{CE0}	collector-emitter voltage	-40	V
I_c	collector current (DC)	-200	mA

Equivalent Circuit & Pinning

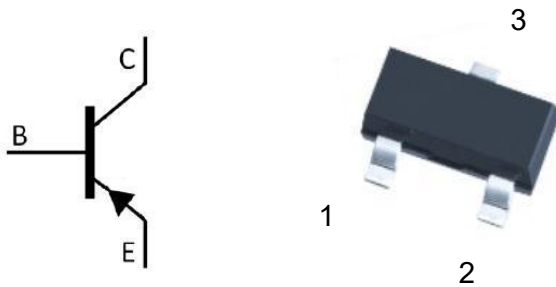

PIN1: Base

PIN 2: Emitter

PIN 3: Collector

hFE Classifications & Marking

h _{FE} Range	100~300
Marking	H2A

Absolute Maximum Ratings(Ta=25°C)

Parameter	Symbol	Rating	Unit
Collector to Base Voltage	V_{CB0}	-40	V
Collector to Emitter Voltage	V_{CEO}	-40	V
Emitter to Base Voltage	V_{EBO}	-5.0	V
Collector Current	I_C	-200	mA
Collector Power Dissipation	P_C	300	mW
Junction Temperature	T_j	150	°C
Storage Temperature Range	T_{stg}	-55~150	°C

Electrical Characteristics(Ta=25°C)

Parameter	Symbol	Test Conditions	Min	Typ	Max	Unit
Collector to Base Breakdown Voltage	V_{CB0}	$I_C=-10\mu A$ $I_E=0$	-40			V
Collector to Emitter Breakdown Voltage	V_{CEO}	$I_C=-1.0mA$ $I_B=0$	-40			V
Emitter to Base Breakdown Voltage	V_{EBO}	$I_E=-10\mu A$ $I_C=0$	-5.0			V
Collector Cut-Off Current	I_{CB0}	$V_{CB}=-30V$ $I_E=0$			-0.05	μA
Emitter Cut-Off Current	I_{EBO}	$V_{EB}=-3.0V$ $I_C=0$			-0.05	μA
DC Current Gain	$h_{FE(1)}$	$V_{CE}=-1.0V$ $I_C=-10mA$	100		300	
	$h_{FE(2)}$	$V_{CE}=-1.0V$ $I_C=-100mA$	30			
	$h_{FE(3)}$	$V_{CE}=-1.0V$ $I_C=-50mA$	60			
	$h_{FE(4)}$	$V_{CE}=-1.0V$ $I_C=-1.0mA$	80			
	$h_{FE(5)}$	$V_{CE}=-1.0V$ $I_C=-0.1mA$	60			
Collector-Emitter Saturation voltage	$V_{CE(sat)(1)}$	$I_C=-10mA$ $I_B=-1.0mA$			-0.25	V
	$V_{CE(sat)(2)}$	$I_C=-50mA$ $I_B=-5.0mA$			-0.4	V
Base-Emitter Saturation Voltage	$V_{BE(sat)(1)}$	$I_C=-10mA$ $I_B=-1.0mA$	-0.65		-0.85	V
	$V_{BE(sat)(2)}$	$I_C=-50mA$ $I_B=-5.0mA$			-0.95	V
Transition Frequency	f_T	$V_{CE}=-20V$ $I_C=-10mA$ $f=100MHz$	250			MHz

Electrical Characteristics(Ta=25°C)

Parameter	Symbol	Test Conditions	Min	Typ	Max	Unit
Output Capacitance	C_{ob}	$V_{CB}=-5.0V$ $f=1.0MHz$			4.5	pF
Storage Time	t_{stg}	$V_{CC}=-3.0V$ $I_C=-10mA$ $I_{B1}=-I_{B2}=-1.0mA$			225	ns
Fall Time	t_f	$V_{CC}=-3.0V$ $I_C=-10mA$ $I_{B1}=-I_{B2}=-1.0mA$			75	ns
Delay Time	t_d	$V_{CC}=-3.0V$ $V_{BE}=-0.5V$ $I_C=-10mA$ $I_{B1}=-1.0mA$			35	ns
Rise Time	t_r	$V_{CC}=-3.0V$ $V_{BE}=-0.5V$ $I_C=-10mA$ $I_{B1}=-1.0mA$			35	ns
Input Capacitance	C_{ib}	$V_{EB}=-0.5V$ $f=1.0MHz$			10	pF

Electrical Characteristic Curve

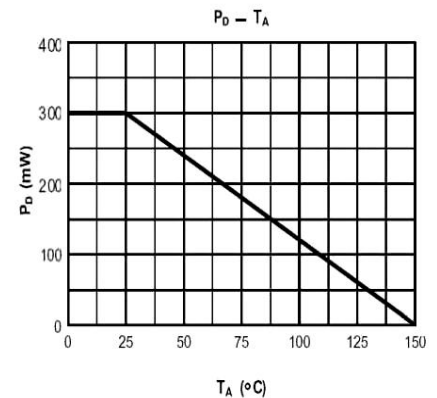
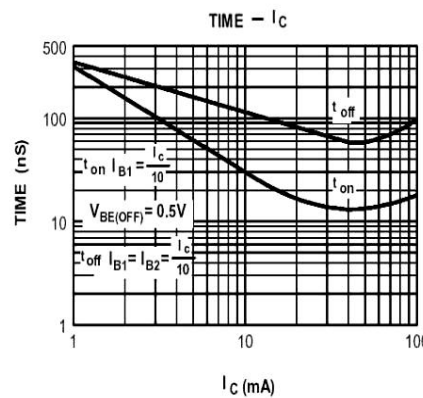
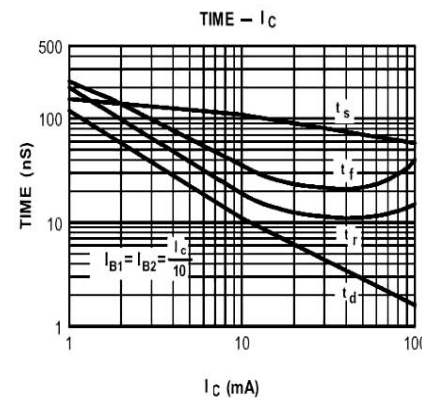
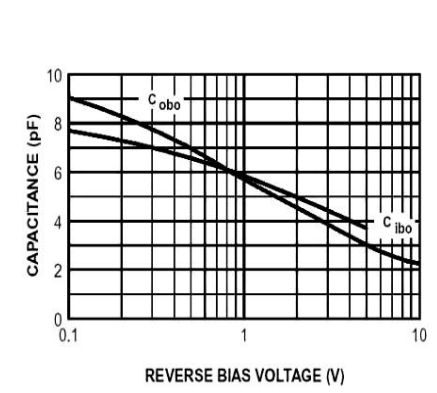
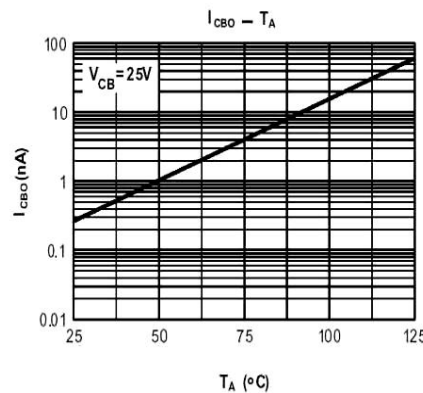
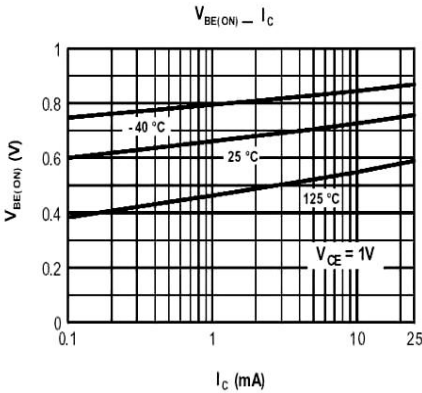
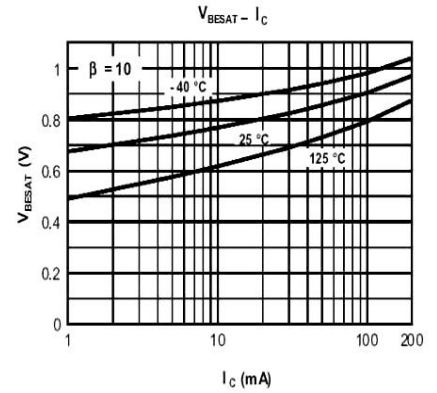
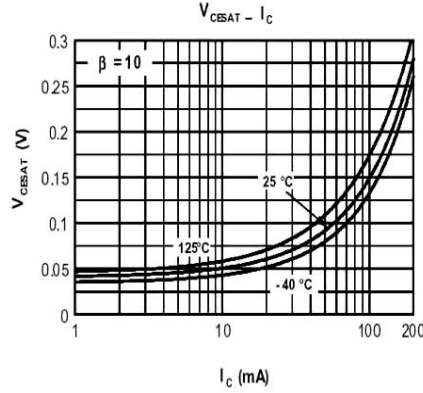
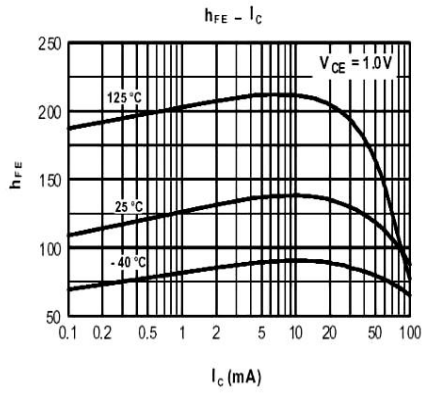

Marking Instructions

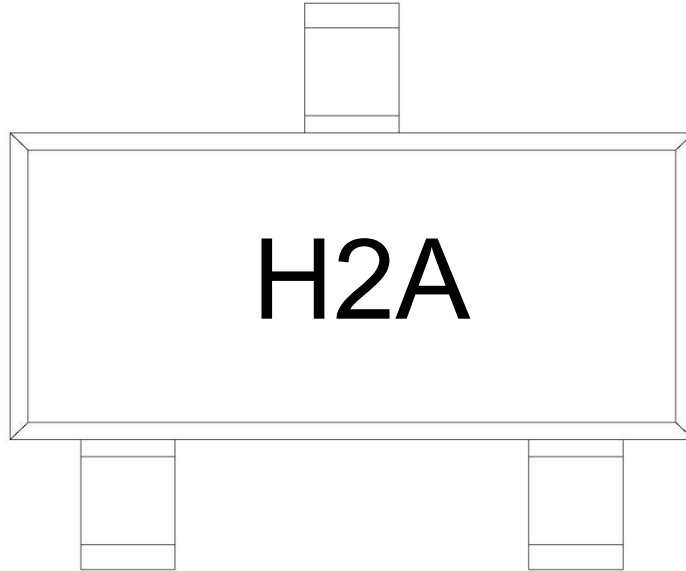

Note:

H: Company Code

2A: Product Type Code

Packaging SPEC.

REEL INFORMATION

Package Type	Units					Dimension (unit: mm ³)		
	Units/Reel	Reels/Inner Box	Units/Inner Box	Inner Boxes/Outer Box	Units/Outer Box	Reel	Inner Box	Outer Box
SOT-23	3,000	10	30,000	6	180,000	7" x8	180×120×180	390×385×205

Package Outline Dimensions

SOT-23

单位: mm

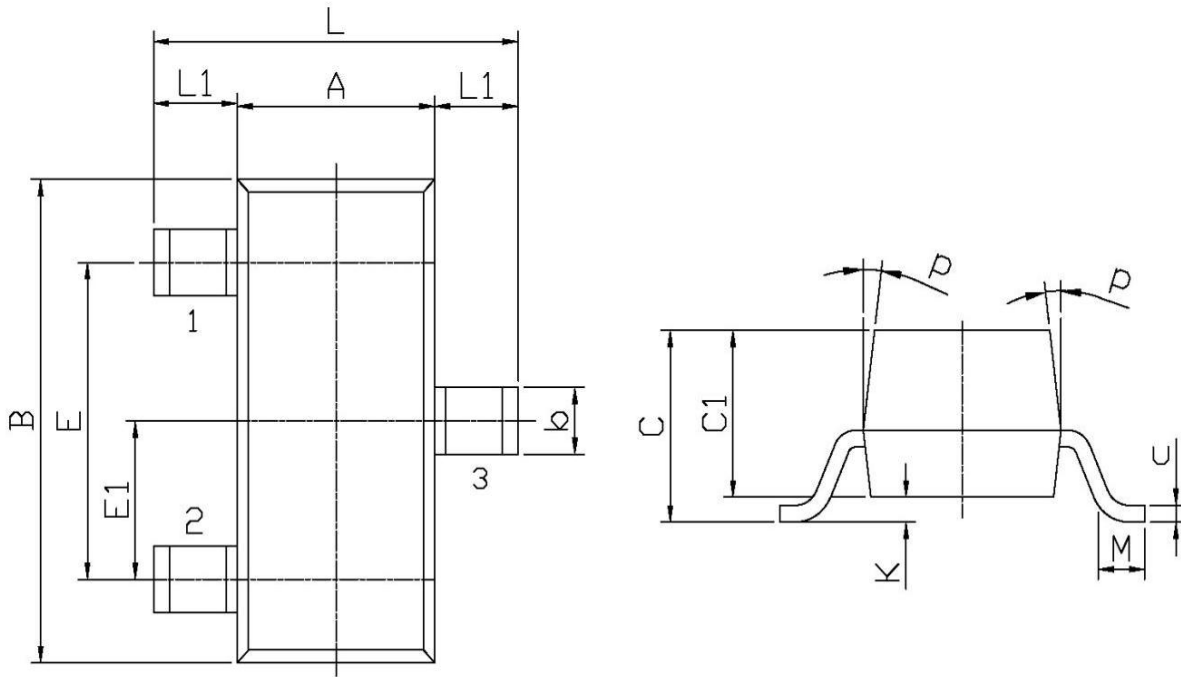

Symbol	Dimensions In Millimeters		Symbol	Dimensions In Millimeters	
	Min	Max		Min	Max
L	2.2	2.7	C	1.30Max	
L1	0.45	0.65	C1	0.90	1.20
A	1.15	1.50	c	0.05	0.20
B	2.70	3.10	K	0	0.10
E	1.70	2.10	M	0.20MIN	
E1	0.85	1.05	P	7°	
b	0.35	0.55			