

Descriptions

The CTCL4054DME is a complete CC/CV linear charger for single cell lithium-ion batteries, It has the function of positive and negative electrode protection for battery. Its SOT23-5 package and low external component count make the CTCL4054DME ideally suited for portable applications. Furthermore, the CTCL4054DME is specifically designed to work within USB power specifications. No external sense resistor is needed and no blocking diode is required due to the internal P-MOSFET architecture. Thermal feedback regulates the charge current to limit the die temperature during high power operation or high ambient temperature. The charge voltage is fixed at 4.2V, and the charge current can be programmed externally with a single resistor. The CTCL4054DME automatically terminates the charge cycle when the charge current drops to 1/10th the programmed value after the final float voltage is reached. When the input supply (wall adapter or USB supply) is removed the CTCL4054DME automatically enters a low current state dropping the battery drain current to less than 3 μ A. Other features include charge current monitor, under-voltage lockout, automatic recharge and two status pins to indicate charge and charge termination.

Features

- Preset 4.20V charge voltage with $\pm 1\%$ accuracy
- Maximum allowable input voltage is 8V
- With BAT-VIN anti-backflow function
- Linear charge mode, built-in 800mA MOSFET, Trickle /Constant current/Constant voltage three stage charging, externally adjustable charging current
- Supports 0V battery charging
- Short circuit protection, battery polarity reverse polarity protection
- Charges single cell Li-ion batteries Directly from USB port
- Intelligent temperature control technology, charging current will decrease with increasing temperature, 130 $^{\circ}$ C began to decline, the lowest can be reduced to 0
- Soft-Start limits inrush current
- Automatic recharge
- 4KV ESD (HBM mode)
- Halogen-free Product

Applications

- Suitable for USB power and adapter power, Bluetooth applications and other portable devices

Pinning And Typical Application

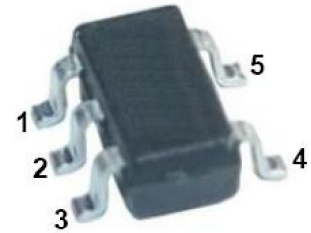
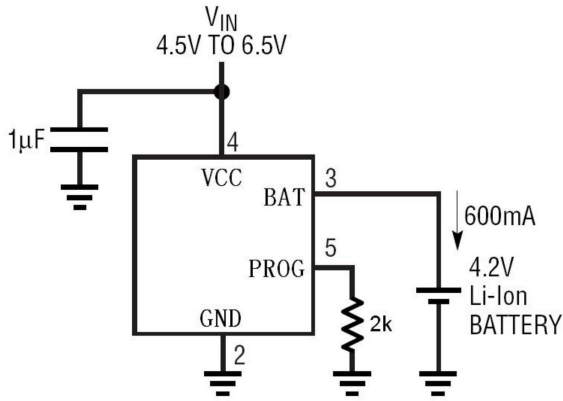

Pin Number	Pin Name	Pin Description
1	CHRG	Charging indicator
2	GND	Chip ground
3	BAT	Battery input
4	VDD	External input DC 5V
5	PROG	Charge current regulator

Marking

See Marking Instructions.

Absolute Maximum Ratings(Ta=25°C)

Parameter	Symbol	Rating	Unit
VDD to GND	V _{DD}	-0.3~8	V
BAT to GND	V _{BAT}	-0.3~7	V
CHRG to GND	V _{chrg}	-0.3~8	V
PROG to GND	V _{prog}	-0.3~8	V
Storage Temperature	T _{STG}	-50~+125	°C
Operating Temperature Range	T _{opr}	-40~+85	°C
Lead Temperature (Soldering, 10s)	T _{solder}	260	°C

Electrical Characteristics(Ta=25°C)

Parameter	Symbol	Test Conditions	Min	Typ	Max	Unit
输入电压范围	V _{DD}		4	5	6	V
V _{DD} 从低到高	V _{DD} 掉电监测	V _{DD} >BAT		100		mV
V _{DD} 从高到低		V _{DD} >BAT		30		mV
浮充门槛电压	V _{BAT}	V _{DD} =5V	4.158	4.20	4.242	V
BAT倒灌电流	I _{BAT}	V _{CC} =3.5V V _{bat} =4.2V		±0.5	±5	µA
涓流转恒流	V _{TRKL}	V _{BAT} 从低到高		2.8		V
涓流充电迟滞电压	V _{TRHYS}			100		mV
V _{DD} 欠压闭锁门限	V _{UV}	V _{DD} 从低到高		3.7		V
V _{DD} 欠压闭锁迟滞	V _{UVHYS}			200		mV
手动停机门限电压	V _{msd}			1.2		V
手动停机迟滞电压	V _{msdHYS}			50		mV
涓流时PROG电压	V _{prog1}			0.1		V
大电流时PROG电压	V _{prog2}			1.0		V
过温恢复	OTR	V _{DD} =5V		130		°C

Description of the Principle

The BRCL4054DME is a complete CC/CV linear charger for single cell lithium-ion batteries. CC/CV to charger batter by internal MOSFET. It can deliver up to 800mA of charge current .No blocking diode or external current sense resistors required. BRCL4054DME include one Open-Drain charge status Pin: Charge status indicator CHRГ.

The internal thermal regulation circuit reduces the programmed charge current if the die temperature attempts to rise above a preset value of approximately 130°C. This feature protects the BRCL4054DME from excessive temperature, and allows the user to push the limits of the power handling capability of a given circuit the external components. Another benefit of adopting thermal regulation is that charge current can be set according to typical, not worst-case, ambient temperatures for a given application with the assurance that the charger will automatically reduce the current in worst-case conditions.

The charge cycle begins when the voltage at the VCC pin rises above the UVLO level, a current set resistor is connected from the PROG pin to ground. The CHRГ pin outputs a logic low to indicate that the charge cycle is on going. At the beginning of the charge cycle, if the battery voltage is below 2.8V, the charge is in pre charge mode to bring the cell voltage up to a safe level for charging. The charger goes into the fast charge CC mode once the voltage on the BAT pin rises above 2.8V. In CC mode, the charge current is set by RPROG. When the battery approaches the regulation voltage 4.2V, the charge current begins to decreases the BRCL4054DME enters the CV mode. When the current drops to charge termination threshold, the charge cycle is terminated, and CHRГ pin assumes a high impedance state to indicate that the charge cycle is terminated. The charge termination threshold is 10% of the current in CC mode.

Description of the Principle

To restart the charge cycle, remove the input voltage and reapply it. The charge cycle can also be automatically restarted if the BAT pin voltage falls below the recharge threshold. The on-chip reference voltage, error amplifier and the resistor divider provide regulation voltage with 1% accuracy which can meet the requirement of lithium-ion and lithium polymer batteries. When the input voltage is not present, or input voltage is below VBAT, the charger goes into a sleep mode, dropping battery drain current to less than 3μA. This greatly reduces the current drain on the battery and increases the standby time.

The charge current is programmed using a single resistor from the PROG pin to ground. The program resistor and the charge current are calculated using the following equations.

$$R_{\text{prog}}(\text{kohm}) = \frac{1200}{I_{\text{bat}}(\text{mA})} \quad (\text{误差} \pm 10\%)$$

Marking Instructions

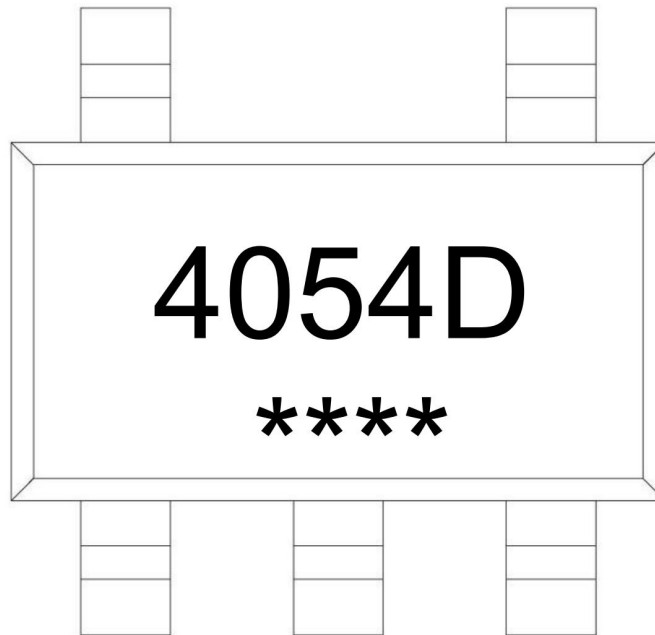

Note:
4054D:
****:

Product Type.
Lot No. Code, code change with Lot No.

Packaging SPEC

REEL

Package Type	Units					Dimension (unit: mm ³)		
	Units/Reel	Reels/Inner Box	Units/Inner Box	Inner Boxes/Outer Box	Units/Outer Box	Reel	Inner Box	Outer Box
SOT23-5/6	3,000	10	30,000	4	120,000	7" ×8	210×205×205	445×230×435

Package Dimensions

