

Descriptions

This 80A, 70V N-Channel MOSFET in a TO-252 Plastic Package.

Features

- Low $R_{DS(on)}$,
- Low gate charge,
- Low C_{iss} ,
- Fast switching.
- Halogen-free Product.

Applications

- Suited for AD-DC Power switch
- DC-DC Power converter
- High Voltage H-Bridge PWM Motor Drive

Equivalent Circuit

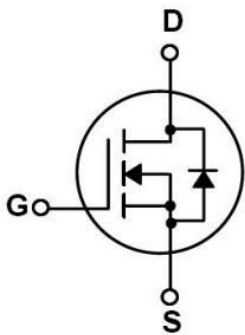

Pinning

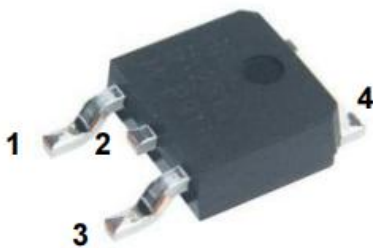

PIN1: Gate PIN 2: Drain PIN 3: Source PIN 4: Drain

Absolute Maximum Ratings(Ta=25°C)

Parameter	Symbol	Rating	Unit	
Drain-Source Voltage	V_{DSS}	70	V	
Drain Current ^G	$I_D(T_C=25^\circ\text{C})$	80	A	
	$I_D(T_C=100^\circ\text{C})$	62	A	
Drain Current - Pulsed ^C	I_{DM}	308	A	
Gate-Source Voltage	V_{GS}	± 20	V	
Single Pulsed Avalanche Energy(L=0.5mH)	E_{AS}	350	mJ	
Avalanche Current	I_{AS}	30	A	
Power Dissipation ^B	$P_D(T_C=25^\circ\text{C})$	135	W	
	$P_D(T_C=100^\circ\text{C})$	68	W	
Operating and Storage Temperature Range	T_J, T_{STG}	-55 to 150	°C	
Maximum Junction-to-Ambient ^A	Steady-State	$R_{\theta JA}$	58	°C/W
Maximum Junction-to-Case ^B	Steady-State	$R_{\theta JC}$	0.93	°C/W

Electrical Characteristics(Ta=25°C)

Parameter	Symbol	Test Conditions	Min	Typ	Max	Unit
Drain-Source Breakdown Voltage	BV_{DSS}	$V_{GS}=0V$ $I_D=250\mu A$	70			V
Zero Gate Voltage Drain Current	I_{DSS}	$V_{DS}=68V$ $V_{GS}=0V$			1	μA
		$V_{DS}=68V$ $T_J=55^\circ\text{C}$			5	
Gate-Body Leakage Current Forward	I_{GSS}	$V_{GS}=\pm 20V$ $V_{DS}=0V$			100	nA
Gate Threshold Voltage	$V_{GS(th)}$	$V_{DS}=V_{GS}$ $I_D=250\mu A$	2.0	2.8	4.0	V
Total gate charge	$R_{DS(on)}$	$V_{GS}=10V$ $I_D=35A$		5.8	7	m Ω
Drain-Source Diode Forward Voltage	V_{SD}	$V_{GS}=0V$ $I_S=1A$			1.4	V

Electrical Characteristics(Ta=25°C)

Parameter	Symbol	Test Conditions	Min	Typ	Max	Unit
Gate resistance	R_g	$V_{GS}=0V$ $V_{DS}=0V$ $f=1MHz$		1.25		Ω
Input Capacitance	C_{iss}	$V_{DS}=30V$ $V_{GS}=0V$ $f=1.0MHz$		2180		pF
Output Capacitance	C_{oss}			614		pF
Reverse Transfer Capacitance	C_{rss}			110		pF
Total Gate Charge(10V)	Q_g	$V_{GS}=10V$ $V_{DS}=30V$ $I_D=20A$		53	75	nC
Total Gate Charge(4.5V)	Q_g			22	31	nC
Gate Source Charge	Q_{gs}			17	31	nC
Gate Drain Charge	Q_{gd}			5		nC
Turn-On Delay Time	$t_{d(on)}$	$V_{GS}=10V$ $V_{DS}=30V$ $R_L=1.5\Omega$ $R_{GEN}=3\Omega$		18		ns
Turn-On Rise Time	t_r			20		ns
Turn-Off Delay Time	$t_{d(off)}$			33		ns
Turn-Off Fall Time	t_f			4		ns
Body Diode Reverse Recovery Time	t_{rr}	$I_F=20A$ $di/dt=500A/\mu s$		26		ns
Body Diode Reverse Recovery Charge	Q_{rr}	$I_F=20A$ $di/dt=500A/\mu s$		125		nC

- A: The value of $R_{\theta JA}$ is measured with the device in a still air environment with $T_A=25^\circ C$.
- B: The power dissipation PD is based on $T_J(MAX)=150^\circ C$, using junction-to-case thermal resistance, and is more useful in setting the upper dissipation limit for cases where additional heatsinking is used.
- C: Repetitive rating, pulse width limited by junction temperature $T_J(MAX)=150^\circ C$.
- D: The $R_{\theta JA}$ is the sum of the thermal impedance from junction to case $R_{\theta JC}$ and case to ambient.
- E: The static characteristics in Figures 1 to 6 are obtained using $<300 \mu s$ pulses, duty cycle 0.5%max.
- F: These curves are based on the junction-to-case thermal impedance which is measured with the device mounted to a large heatsink, assuming a maximum junction temperature of $T_J(MAX)=150^\circ C$.
- G: The maximum current rating is limited by bond-wires.

Electrical Characteristic Curve

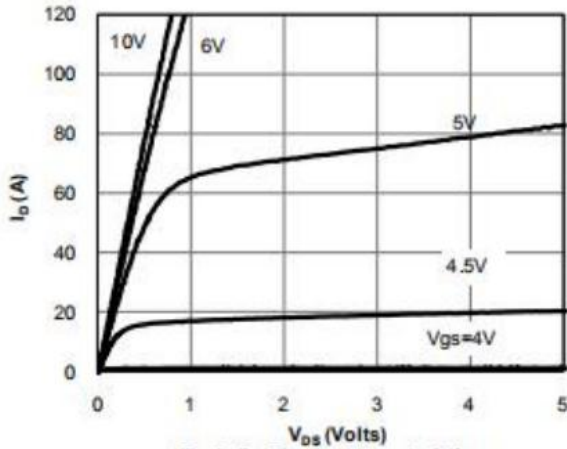

Fig 1: On-Region Characteristics

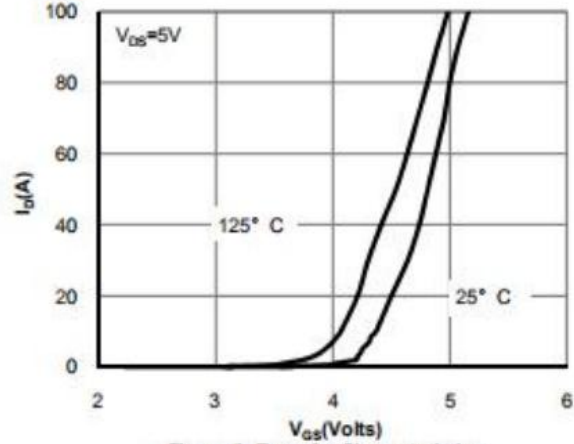

Figure 2: Transfer Characteristics

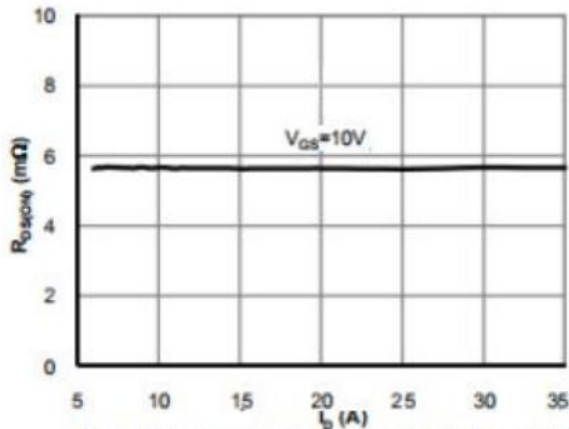

Figure 3: On-Resistance vs. Drain Current and Gate Voltage

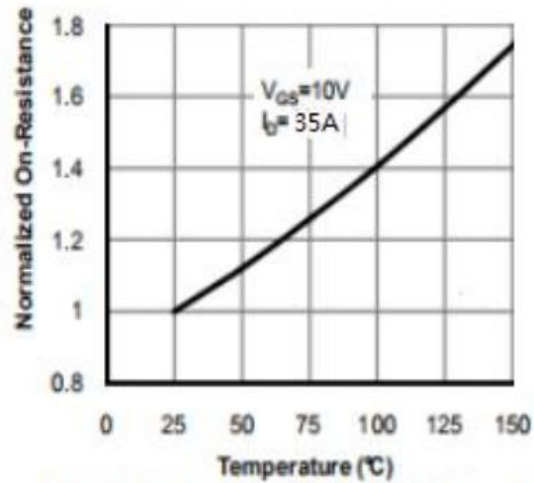

Figure 4: On-Resistance vs. Junction Temperature

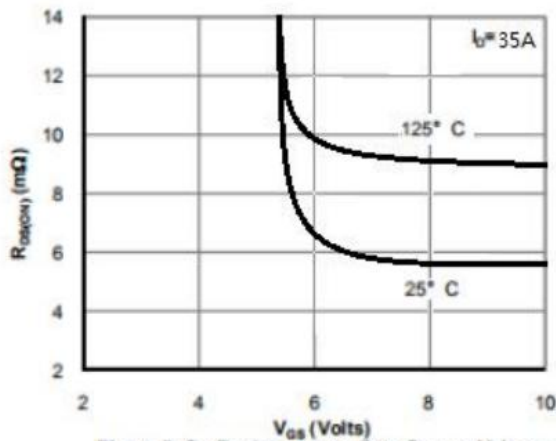

Figure 5: On-Resistance vs. Gate-Source Voltage

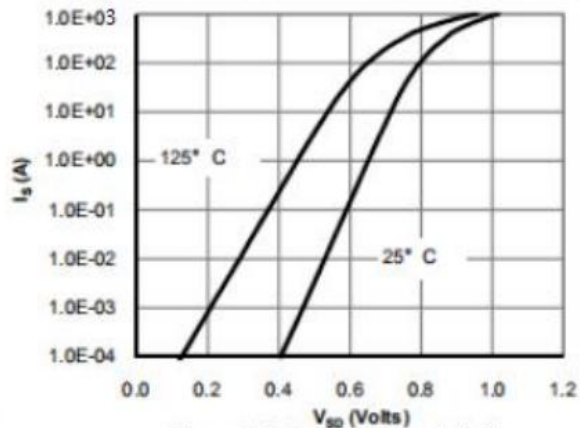

Figure 6: Body-Diode Characteristics

Electrical Characteristic Curve

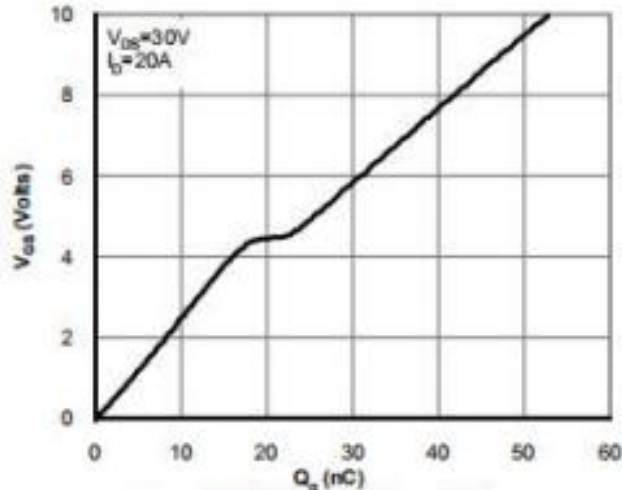

Figure 7: Gate-Charge Characteristics

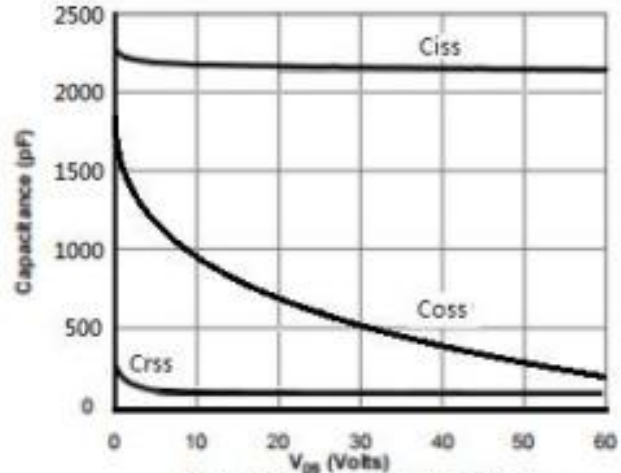

Figure 8: Capacitance Characteristics

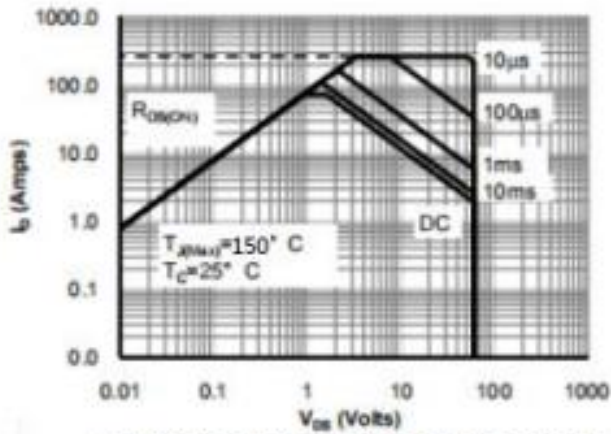

Figure 9: Maximum Forward Biased Safe Operating Area

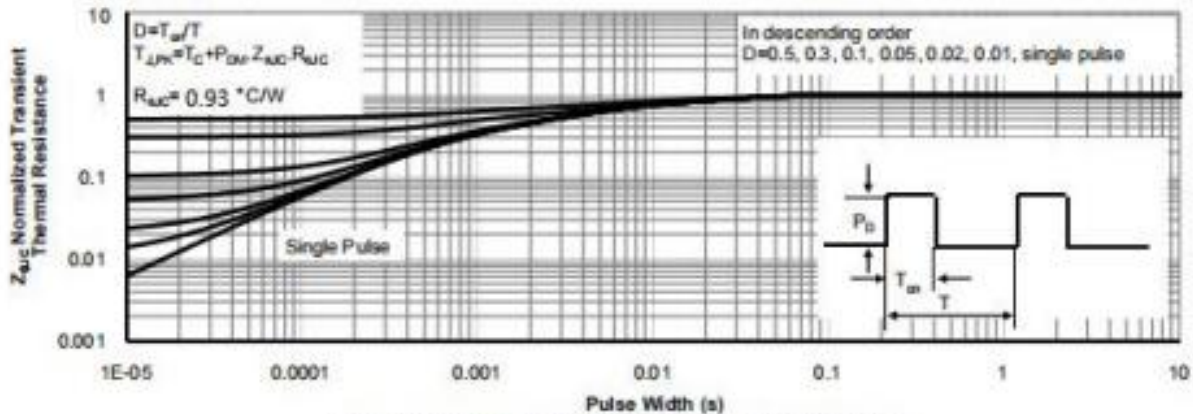

Figure 10: Normalized Maximum Transient Thermal Impedance

Marking Instructions



Note:

COT: Company Logo

80N07: Product Type.

****: Lot No. Code, code change with Lot No.

Packaging SPEC

REEL INFORMATION

Package Type	Units					Dimension (unit: mm ³)		
	Units/Reel	Reels/Inner Box	Units/Inner Box	Inner Boxes/Outer Box	Units/Outer Box	Reel	Inner Box	Outer Box
TO-252	2,500	2	5,000	6	30,000	13" ×16	360×360×50	380×335×366

TUBE INFORMATION

Package Type	Units					Dimension (unit: mm ³)		
	Units/Tube	Tubes/Inner Box	Units/Inner Box	Inner Boxes/Outer Box	Units/Outer Box	Tube	Inner Box	Outer Box
TO-252	75	48	3,600	5	18,000	526×20.5×5.25	555×164×50	575×290×180

Package Outline Dimensions

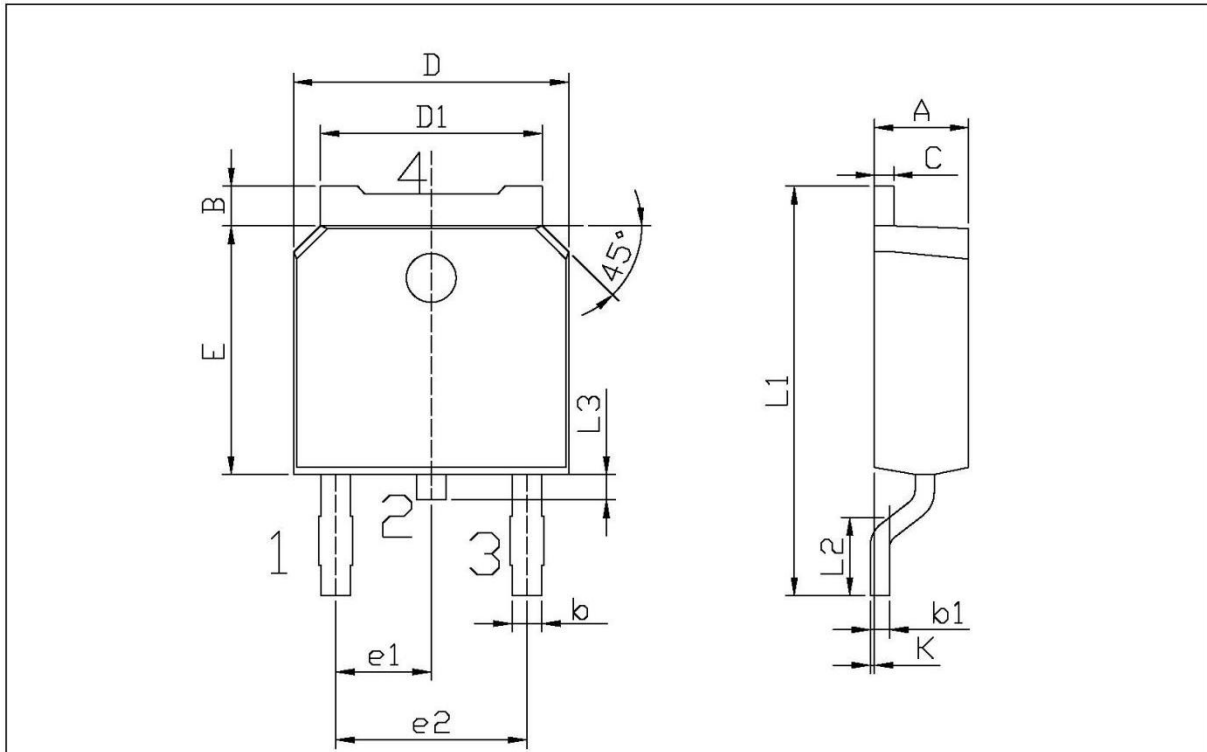

单位: mm

Symbol	Dimensions In Millimeters		Symbol	Dimensions In Millimeters	
	Min	Max		Min	Max
A	2.20	2.40	E	5.95	6.25
B	0.95	1.25	e1	2.24	2.34
b	0.70	0.90	e2	4.43	4.73
b1	0.45	0.55	L1	9.85	10.35
C	0.45	0.55	L2	1.70	2.00
D	6.45	6.75	L3	0.60	0.90
D1	5.10	5.50	K	0.00	0.10

TO-252