

Descriptions

This 30V,45A N-Channel MOSFET in a TO-252 Plastic Package.

Features

- Low RDS(on)
- Low gate charge
- Low Crss
- Fast speed switching
- Halogen-free Product

Applications

Suited for low voltage applications such as automotive, DC/DC Converters, and high efficiency switching for power management in portable and battery operated products

Equivalent Circuit

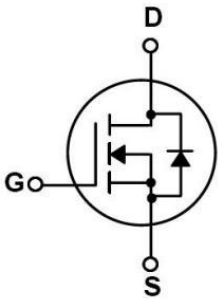

Pinning



PIN1: Gate PIN 2: Drain PIN 3: Source PIN 4: Drain

Absolute Maximum Ratings(Ta=25°C)

| Parameter | Symbol | Rating | Unit |
|--------------------------------|------------------------------|----------|------------------|
| Drain-Source Voltage | V_{DSS} | 30 | V |
| Drain Current | $I_D(T_C=25^\circ\text{C})$ | 45 | A |
| Drain Current | $I_D(T_C=100^\circ\text{C})$ | 35.4 | A |
| Drain Current - Pulsed | I_{DM} | 200 | A |
| Gate-Source Voltage | V_{GS} | ± 20 | V |
| Single Pulsed Avalanche Energy | E_{AS} | 490 | mJ |
| Repetitive Avalanche Energy | E_{AR} | 12 | mJ |
| Power Dissipation | $P_D(T_C=25^\circ\text{C})$ | 30 | W |
| Junction Temperature Range | T_j | 150 | $^\circ\text{C}$ |
| Storage Temperature Range | T_{stg} | -55~150 | $^\circ\text{C}$ |

Electrical Characteristics(Ta=25°C)

| Parameter | Symbol | Test Conditions | Min | Typ | Max | Unit |
|------------------------------------|---------------|--|-----|------|-----------|-----------|
| Drain-Source Breakdown Voltage | BV_{DSS} | $V_{GS}=0V$ $I_D=250\mu A$ | 30 | | | V |
| Zero Gate Voltage Drain Current | I_{DSS} | $V_{DS}=30V$ $V_{GS}=0V$ | | | 1.0 | μA |
| Gate-Body Leakage Current Forward | I_{GSS} | $V_{GS}=\pm 20V$ $V_{DS}=0V$ | | | ± 0.1 | μA |
| Gate Threshold Voltage | $V_{GS(th)}$ | $V_{DS}=V_{GS}$ $I_D=250\mu A$ | 1 | | 2.5 | V |
| Total Gate Charge | Q_g | $V_{DS}=15V$ $I_D=20A$ $V_{GS}=10V$ | | 14 | 22 | nC |
| Static Drain-Source On-Resistance | $R_{DS(on)1}$ | $V_{GS}=10V$ $I_D=50A$ | | 7 | 9 | $m\Omega$ |
| | $R_{DS(on)2}$ | $V_{GS}=4.5V$ $I_D=25A$ | | | 17 | $m\Omega$ |
| Drain-Source Diode Forward Voltage | V_{SD} | $V_{GS}=0V$ $I_S=50A$ | | | 1.5 | V |
| Input Capacitance | C_{iss} | $V_{DS}=25V$ $V_{GS}=0V$ $f=1.0MHz$ | | 1140 | | pF |
| Output Capacitance | C_{oss} | | | 137 | | |
| Reverse Transfer Capacitance | C_{rss} | | | 118 | | |
| Turn-On Delay Time | $t_{d(on)}$ | $V_{DD}=30V$ $I_D=25A$ $R_G=25\Omega$ | | 20 | 50 | ns |
| Turn-On Rise Time | t_r | | | 100 | 210 | |
| Turn-Off Delay Time | $t_{d(off)}$ | | | 80 | 170 | |
| Turn-Off Fall Time | t_f | | | 85 | 180 | |

Electrical Characteristic Curve

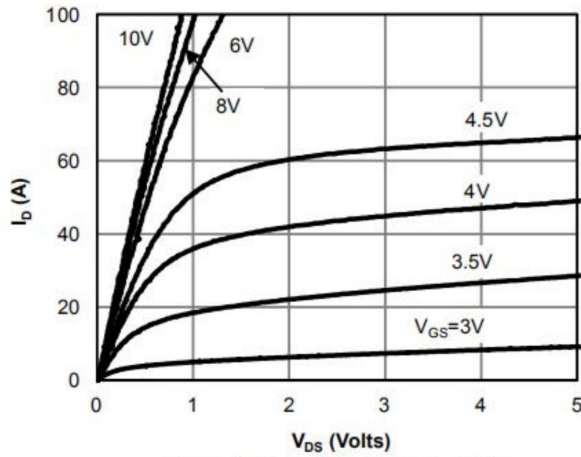

Figure 1: On-Region Characteristics

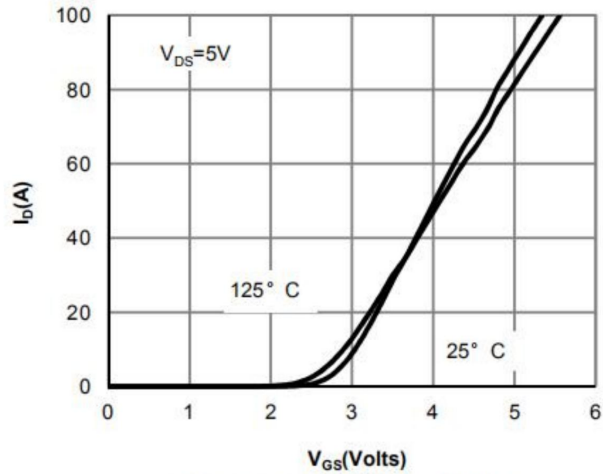

Figure 2: Transfer Characteristics

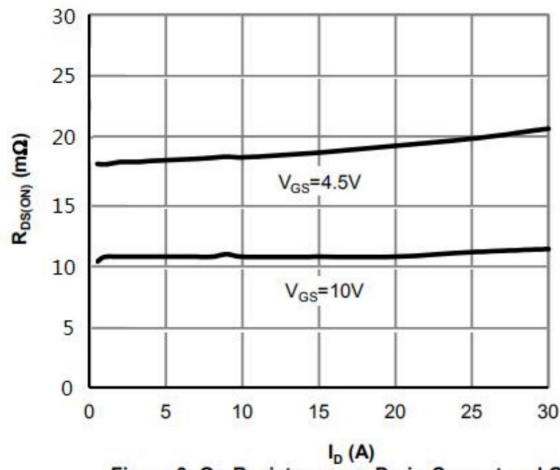

Figure 3: On-Resistance vs. Drain Current and Gate Voltage

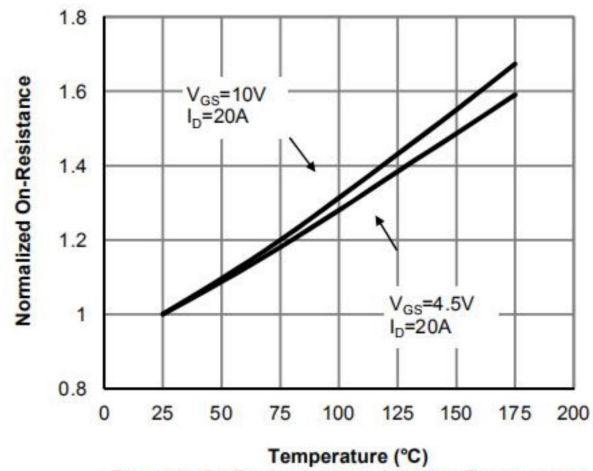

Figure 4: On-Resistance vs. Junction Temperature

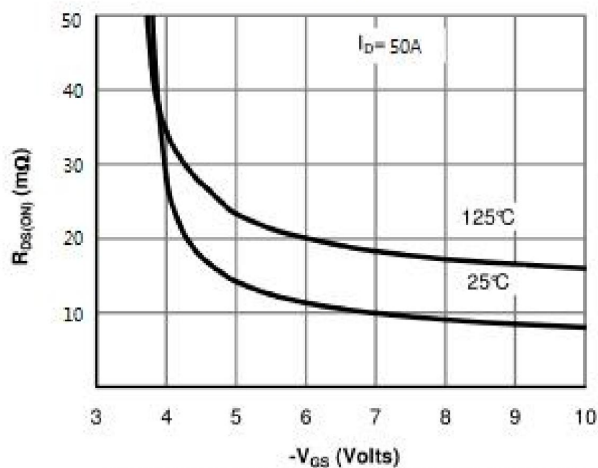

Figure 5: On-Resistance vs. Gate-Source Voltage

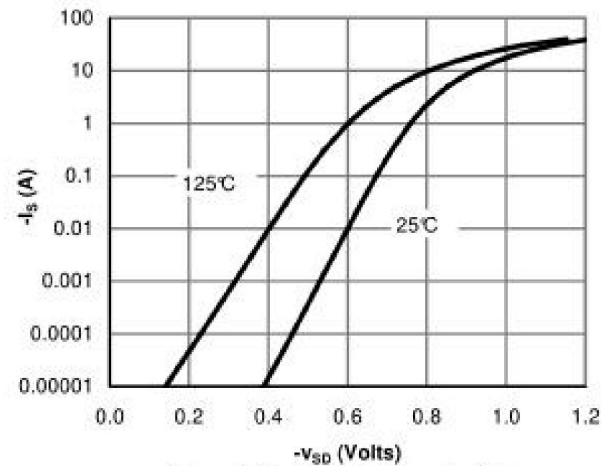

Figure 6: Body-Diode Characteristics

Electrical Characteristic Curve

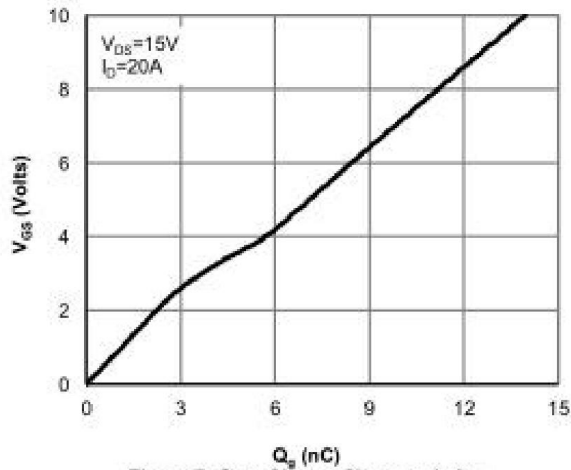

Figure 7: Gate-Charge Characteristics

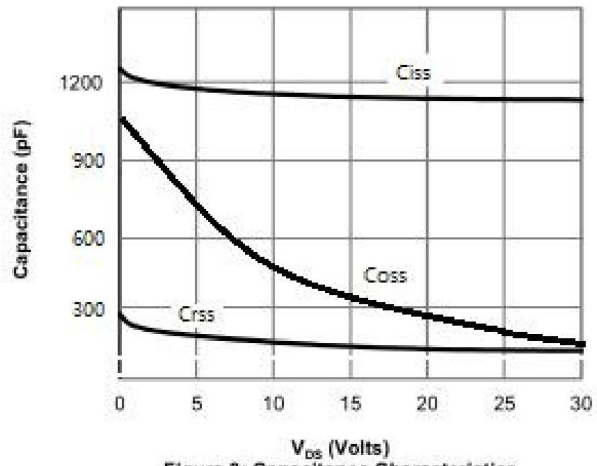

Figure 8: Capacitance Characteristics

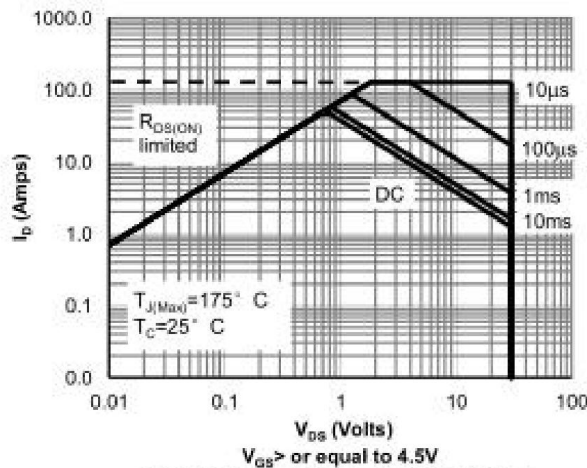

Figure 9: Maximum Forward Biased Safe Operating Area

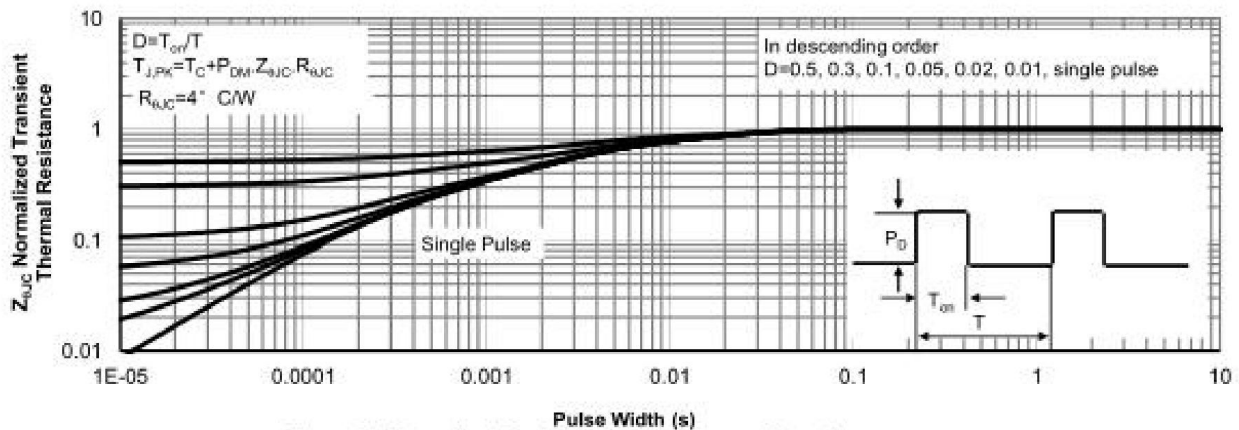

Figure 11: Normalized Maximum Transient Thermal Impedance

Marking Instructions



Note:

COT: Company Code.

50N03: Product Type.

*****: Lot No. Code, code change with Lot No.

Packaging SPEC

REEL INFORMATION

| Package Type | Units | | | | | Dimension (unit: mm ³) | | |
|--------------|------------|-----------------|-----------------|-----------------------|-----------------|------------------------------------|------------|-------------|
| | Units/Reel | Reels/Inner Box | Units/Inner Box | Inner Boxes/Outer Box | Units/Outer Box | Reel | Inner Box | Outer Box |
| TO-252 | 2,500 | 2 | 5,000 | 6 | 30,000 | 13" ×16 | 360×360×50 | 380×335×366 |

TUBE INFORMATION

| Package Type | Units | | | | | Dimension (unit: mm ³) | | |
|--------------|------------|-----------------|-----------------|-----------------------|-----------------|------------------------------------|------------|-------------|
| | Units/Tube | Tubes/Inner Box | Units/Inner Box | Inner Boxes/Outer Box | Units/Outer Box | Tube | Inner Box | Outer Box |
| TO-252 | 75 | 48 | 3,600 | 5 | 18,000 | 526×20.5×5.25 | 555×164×50 | 575×290×180 |

Package Outline Dimensions

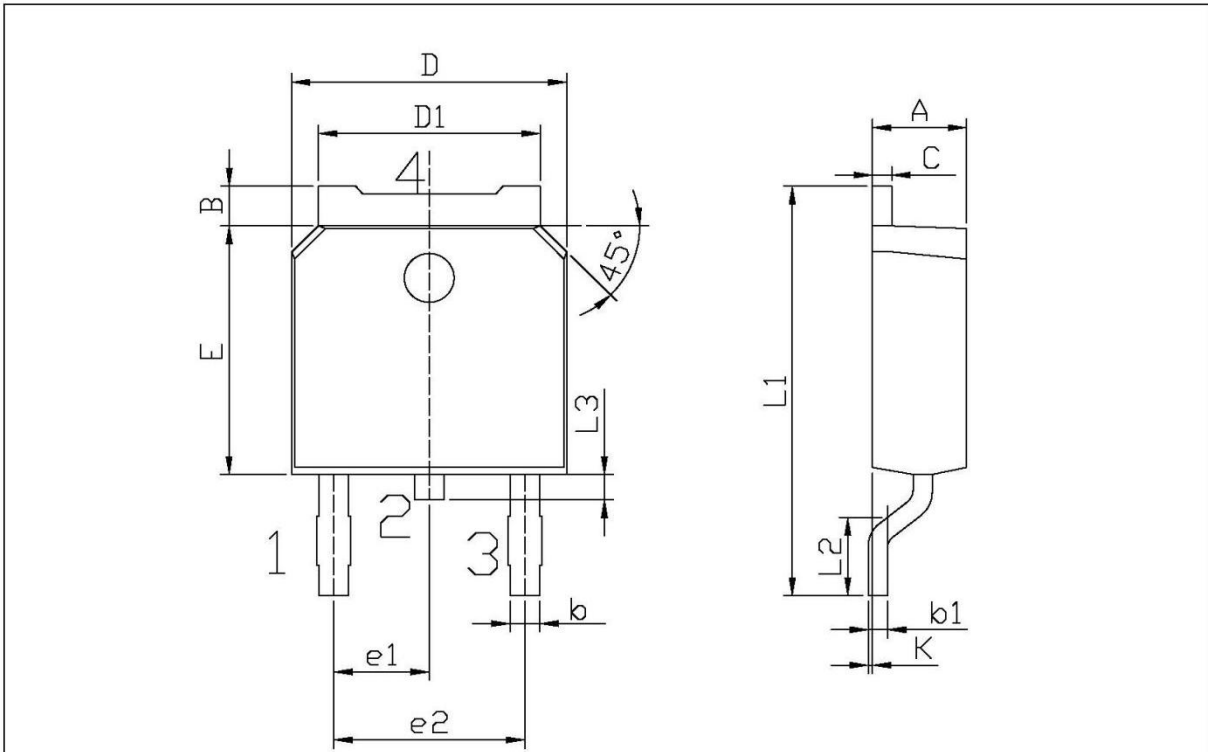

单位: mm

| Symbol | Dimensions In Millimeters | | Symbol | Dimensions In Millimeters | |
|--------|---------------------------|------|--------|---------------------------|-------|
| | Min | Max | | Min | Max |
| A | 2.20 | 2.40 | E | 5.95 | 6.25 |
| B | 0.95 | 1.25 | e1 | 2.24 | 2.34 |
| b | 0.70 | 0.90 | e2 | 4.43 | 4.73 |
| b1 | 0.45 | 0.55 | L1 | 9.85 | 10.35 |
| C | 0.45 | 0.55 | L2 | 1.70 | 2.00 |
| D | 6.45 | 6.75 | L3 | 0.60 | 0.90 |
| D1 | 5.10 | 5.50 | K | 0.00 | 0.10 |

TO-252