

Descriptions

This 100V 150A N-channel mosfet in a TO-220 plastic package.

Features

- Ultra low on-resistance
- Fast switching

Applications

- High frequency switching and synchronous rectification
- BMS
- Motor

Equivalent Circuit

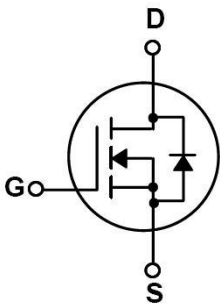

Pinning

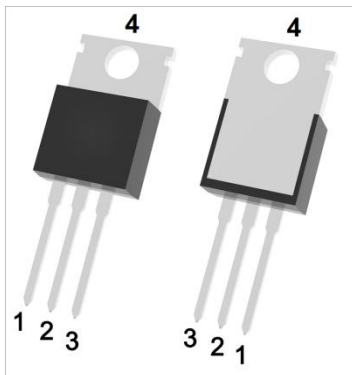

PIN1: G

PIN 2, 4: D

PIN 3: S

Marking

See Marking Instructions.

Absolute Maximum Ratings(Ta=25°C)

Parameter	Symbol	Rating	Unit
Drain-Source Voltage	V _{DSS}	100	V
Drain Current	I _D (T _C =25°C)	150	A
Pulsed Drain Current	I _{DM}	319	A
Gate-Source Voltage	V _{GS}	±20	V
Single Pulsed Avalanche Energy(L=0.5mH)	E _{AS}	381	mJ
Avalanche Current	I _{AS}	33	A
Total Power Dissipation	P _D (T _C =25°C)	180	W
Junction and Storage Temperature Range	T _J , T _{STG}	-55 to 150	°C
Thermal Resistance-Junction to Ambient	≤10s	R _{θJA}	17
	Steady-State		62.5
Thermal Resistance-Junction to Case	Steady-State	R _{θJC}	0.69

Electrical Characteristics(Ta=25°C)

Parameter	Symbol	Test Conditions	Min	Typ	Max	Unit
Drain-Source Breakdown Voltage	BV _{DSS}	V _{GS} =0V I _D =250μA	100	109		V
Zero Gate Voltage Drain Current	I _{DSS}	V _{DS} =100V V _{GS} =0V			1	μA
Gate-Body Leakage Current Forward	I _{GSS}	V _{GS} =±20V V _{DS} =0V			±100	nA
Gate Threshold Voltage	V _{GS(th)}	V _{DS} =V _{GS} I _D =250μA	2	2.6	4	V
Static Drain-Source On-Resistance	R _{DS(on)1}	V _{GS} =10V I _D =20A		3.2	4.5	mΩ
	R _{DS(on)2}	V _{GS} =6V I _D =10A		4.2	6.5	mΩ
Forward On Voltage	V _{SD}	V _{GS} =0V I _S =1A			1.2	V
Gate resistance	R _g	f=1MHz		1.3		Ω
Input Capacitance	C _{iss}	V _{DS} =25V V _{GS} =0V f=1MHz		6950		pF
Output Capacitance	C _{oss}			955		
Reverse Transfer Capacitance	C _{rss}			124		
Total Gate Charge	Q _{g(10V)}	V _{GS} =10V, V _{DS} =50V, I _D =20A		90		nC
Gate Source Charge	Q _{gs}			28		
Gate Drain Charge	Q _{gd}			19		

Electrical Characteristics(Ta=25°C)

Parameter	Symbol	Test Conditions	Min	Typ	Max	Unit
Turn-On Delay Time	$t_{d(on)}$	$V_{GS}=10V$ $V_{DS}=50V$ $R_L=2.5\Omega$ $R_{GEN}=3\Omega$		27		ns
Turn-On Rise Time	t_r			20		
Turn-Off Delay Time	$t_{d(off)}$			50		
Turn-Off Fall Time	t_f			25		

Electrical Characteristic Curve

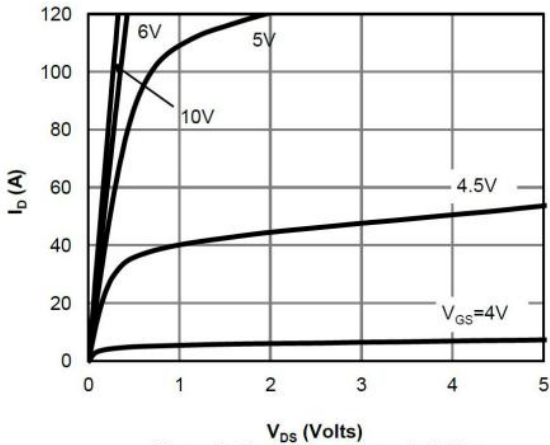

Figure 1: On-Region Characteristics

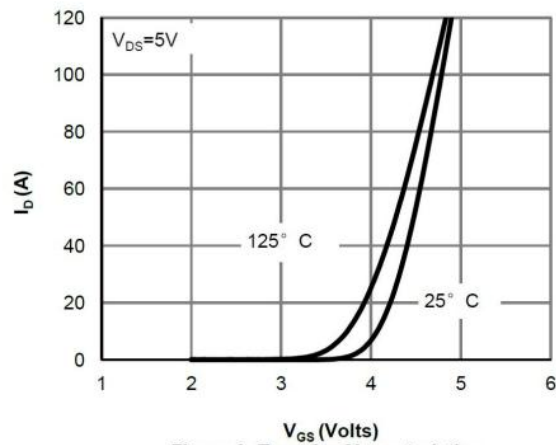

Figure 2: Transfer Characteristics

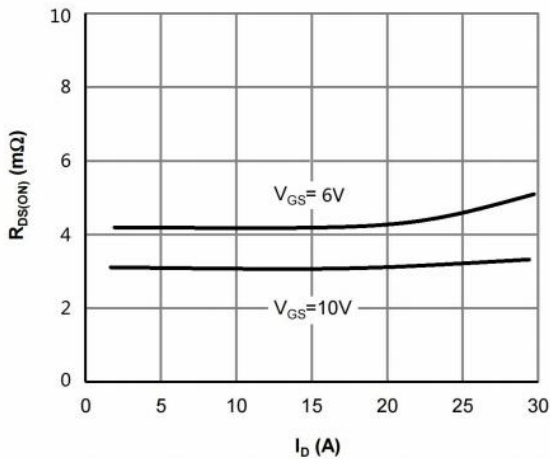

Figure 3: On-Resistance vs. Drain Current and Gate Voltage

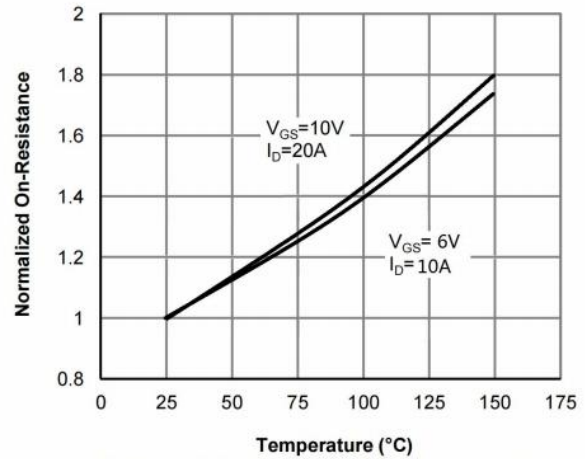

Figure 4: On-Resistance vs. Junction Temperature

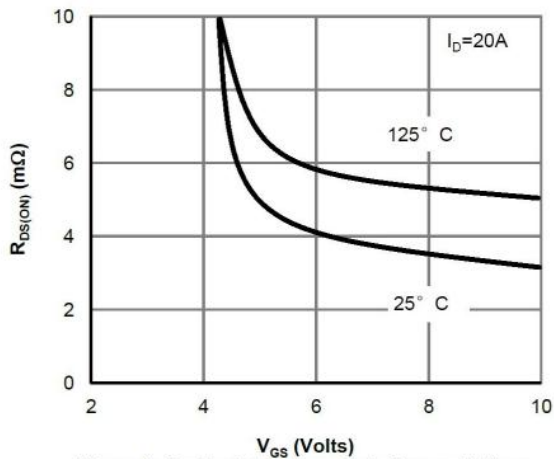

Figure 5: On-Resistance vs. Gate-Source Voltage

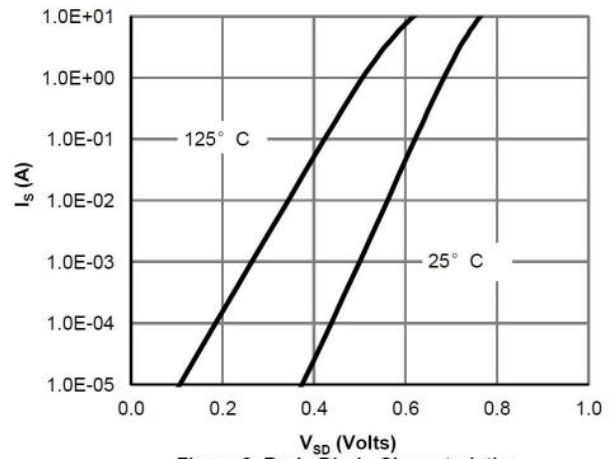

Figure 6: Body-Diode Characteristics

Electrical Characteristic Curve

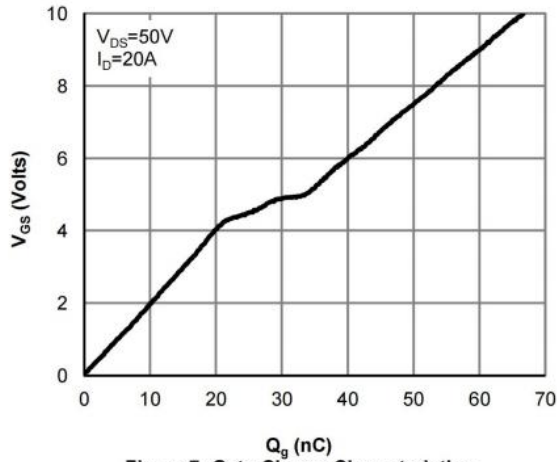

Figure 7: Gate-Charge Characteristics

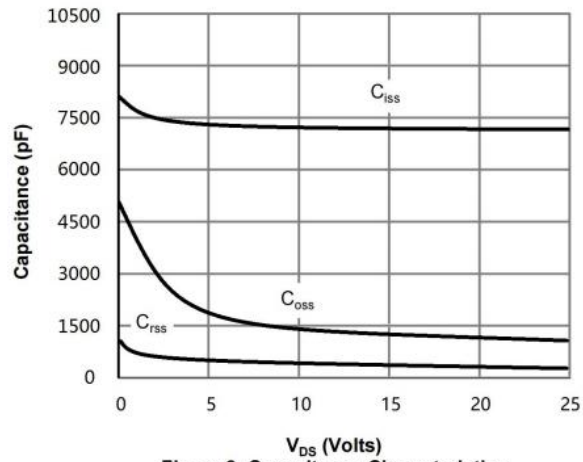

Figure 8: Capacitance Characteristics

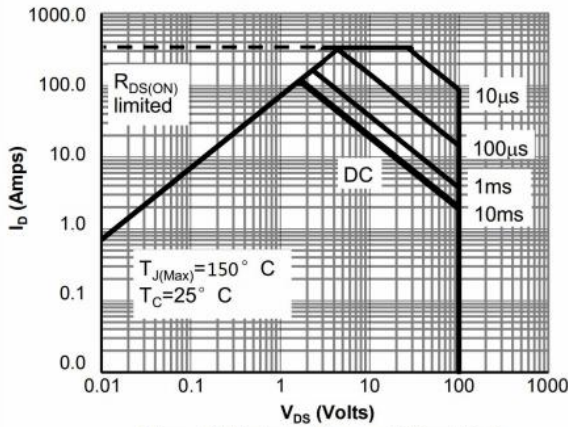

Figure 9: Maximum Forward Biased Safe Operating Area

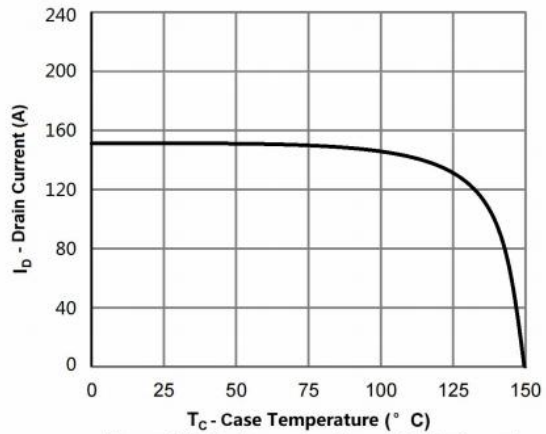

Figure 10: Maximum Continuous Drain Current vs Case Temperature

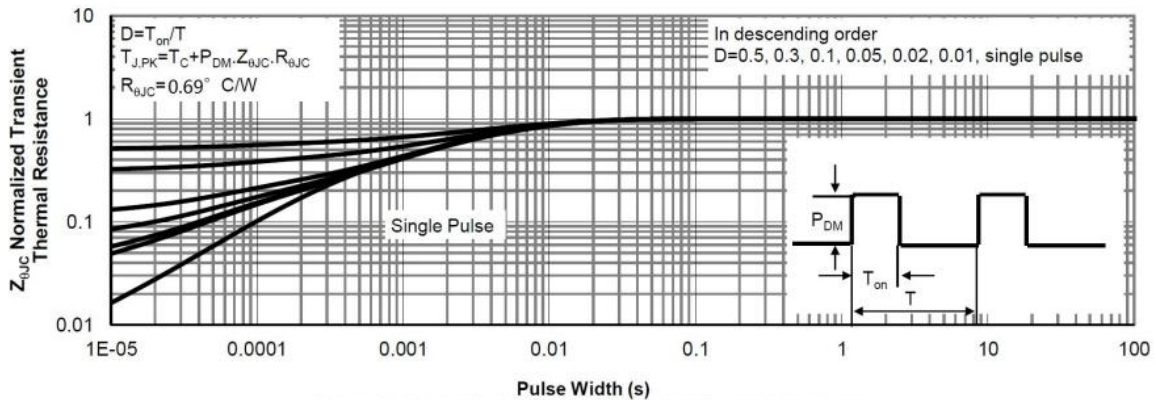
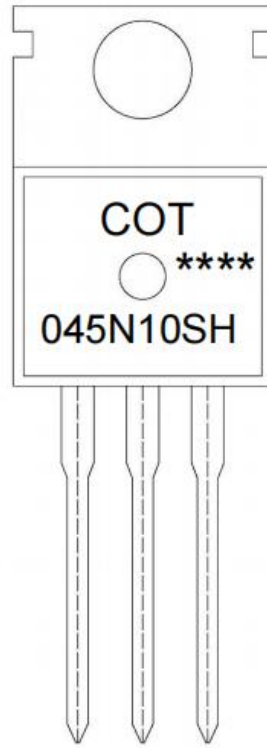

Figure 11: Normalized Maximum Transient Thermal Impedance

Marking Instructions



Note:

COT: Company Code.

045N10SH: Product Type Code

****: Lot No. Code, code change with Lot No.

Packaging SPEC

BULK

Package Type	Units					Dimension (unit: mm ³)		
	Units/Bag	Bags/Inner Box	Units/Inner Box	Inner Boxes/Outer Box	Units/Outer Box	Bag	Inner Box	Outer Box
TO-220/F	200	10	2,000	5	10,000	135×190	237×172×102	560×245×195

TUBE

Package Type	Units					Dimension (unit: mm ³)		
	Units/Tube	Tubes/Inner Box	Units/Inner Box	Inner Boxes/Outer Box	Units/Outer Box	Tube	Inner Box	Outer Box
TO-220/F	50	20	1,000	5	5,000	532×31.4×5.5	555×164×50	575×290×180

Package Outline Dimensions

TO-220

单位: mm

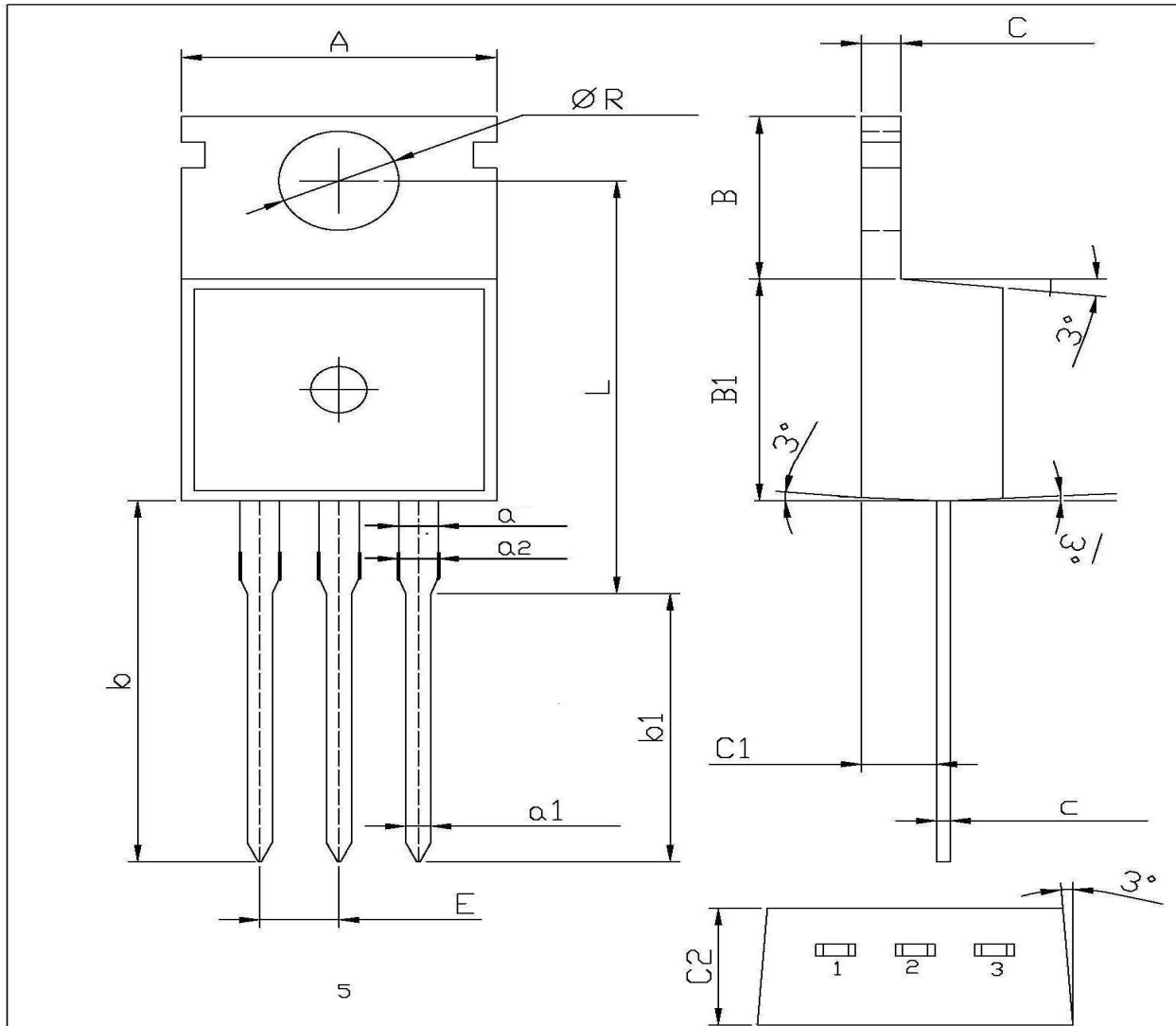

Symbol	Dimensions In Millimeters		Symbol	Dimensions In Millimeters	
	Min	Max		Min	Max
A	9.8	10.2	C	1.2	1.4
R	3.56	3.64	B	6.3	6.7
L	15.7	16.1	B1	9.0	9.4
b	12.6	13.6	C1	2.2	2.6
b1	9.6	10.6	a1	0.7	0.9
a	1.22	1.32	c	0.4	0.6
E	2.34	2.74	C2	4.3	4.7
a2	1.25	1.45			