

Descriptions

These N-channel MOSFET are produced using advanced plane MOSFET Technology, which provides Low on-state resistance, high switching performance and excellent quality.

These devices are suitable device for SMPS, high Speed switching and general purpose applications.

Features

- Low $R_{DS(on)}$
- Low gate charge
- Low C_{rss}
- Fast switching

Applications

- Halogen-free product
- Suited for low voltage applications such as automotive
- DC/DC Converters
- and high efficiency switching for power management in portable and battery operated products

Equivalent Circuit

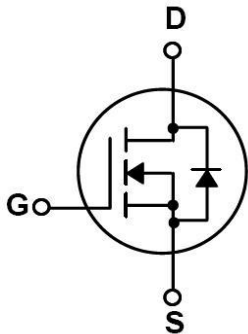

Pinning



PIN1: G PIN 2: D PIN 3: S PIN 4: D

Absolute Maximum Ratings(Ta=25°C)

Parameter	Symbol	Rating	Unit
Drain-Source Voltage	V_{DSS}	650	V
Drain Current	$I_D(T_C=25^\circ C)$	5	A
Drain Current - Pulsed	I_{DM}	20	A
Gate-Source Voltage	V_{GS}	±30	V
Single Pulsed Avalanche Energy	E_{AS}	27	mJ
Avalanche Current	I_{AS}	2.5	A
Power Dissipation	$P_D(T_C=25^\circ C)$	56.5	W
Operating and Storage Temperature Range	T_J, T_{STG}	-55 to 150	°C
Junction-to-Case	$R_{\theta JC}$	2.2	°C/W
Junction-to-Ambient	$R_{\theta JA}$	55	°C/W

Electrical Characteristics(Ta=25°C)

Parameter	Symbol	Test Conditions	Min	Typ	Max	Unit
Drain-Source Breakdown Voltage	BV_{DSS}	$V_{GS}=0V$ $I_D=250\mu A$	650	700		V
Zero Gate Voltage Drain Current	I_{DSS}	$V_{DS}=650V$ $V_{GS}=0V$ $T_J=25^\circ C$			1.0	μA
Gate-Body Leakage Current, Forward	I_{GSS}	$V_{GS}=\pm 30V$			±100	nA
Gate Threshold Voltage	$V_{GS(th)}$	$V_{DS}=V_{GS}$ $I_D=250\mu A$	2.5	3.3	4.0	V
Static Drain-Source On-Resistance	$R_{DS(on)}$	$V_{GS}=10V$ $I_D=2A$		830	1000	mΩ
Drain-Source Diode Forward Voltage	V_{SD}	$V_{GS}=0V$ $I_{SD}=1A$ $T_J=25^\circ C$			1.2	V
Gate Resistance	R_g	$V_{GS} = 0V$ $f = 1.0MHz$		8.5		Ω
Input Capacitance	C_{iss}	$V_{DS}=100V$ $V_{GS}=0V$ $f=1.0MHz$		295		pF
Output Capacitance	C_{oss}			15		pF
Reverse Transfer Capacitance	C_{rss}			0.5		pF
Turn-On Delay Time	$t_{d(on)}$			9.4		ns
Turn-On Rise Time	t_r	$V_{DS}=400V$ $I_D=2A$ $V_{GS}=10V$ $R_G=25\Omega$		22.6		ns
Turn-Off Delay Time	$t_{d(off)}$			36.4		ns
Turn-Off Fall Time	t_f			25.4		ns

Electrical Characteristics(Ta=25°C)

Parameter	Symbol	Test Conditions	Min	Typ	Max	Unit
Continuous Diode Forward Current	I_S				5	A
Total Gate Charge	Q_g	$V_{DS}=520V$ $I_D=2A$ $V_{GS}=10V$		9.1		nC
Gate-Source Charge	Q_{gs}			2.1		nC
Gate-Drain Charge	Q_{gd}			4.0		nC
Reverse recovery time	T_{rr}	$V_R=50V$, $I_F=2A$, $di_F/dt=100A/\mu s$		159		ns
Reverse recovery charge	Q_{rr}			0.93		μC

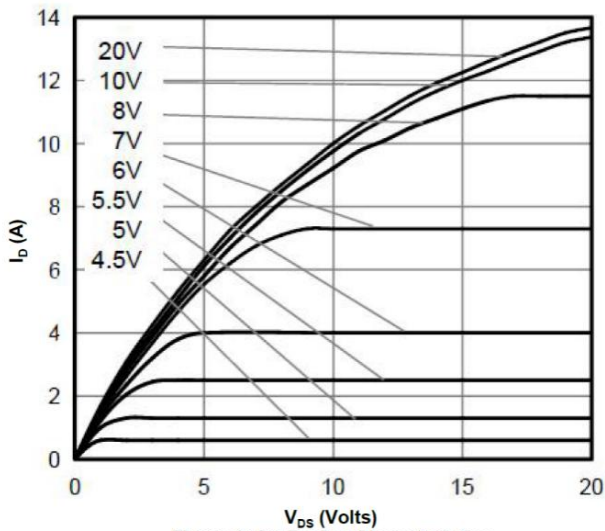

Figure 1: On-Region Characteristics

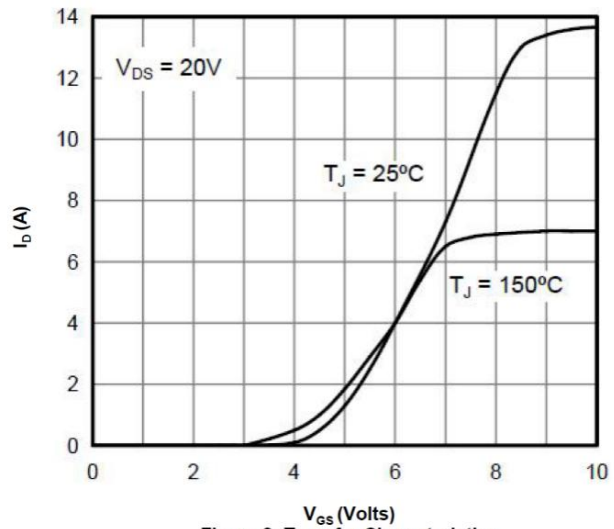

Figure 2: Transfer Characteristics

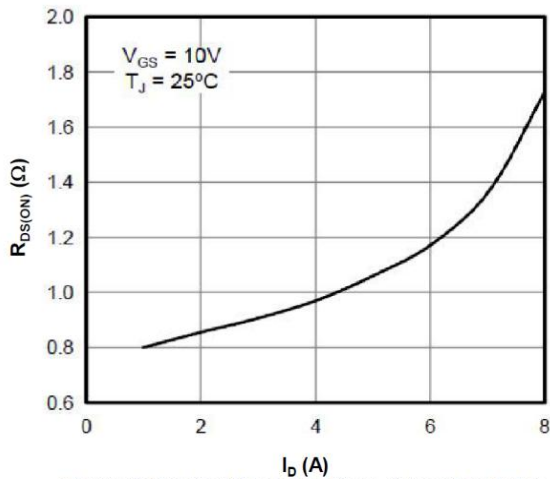

Figure 3: On-Resistance vs. Drain Current and Gate Voltage

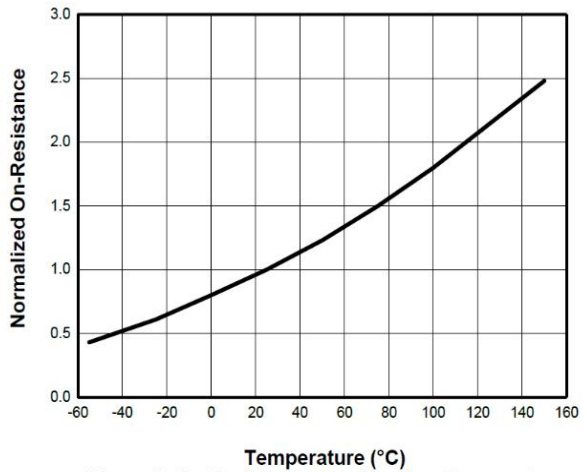

Figure 4: On-Resistance vs. Junction Temperature

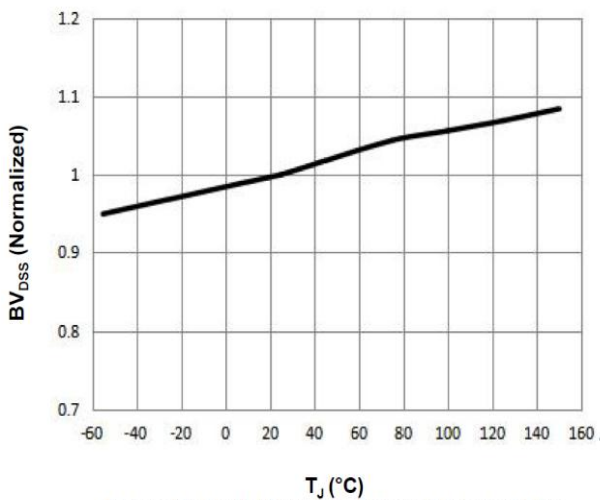

Figure 5: Break Down vs. Junction Temperature

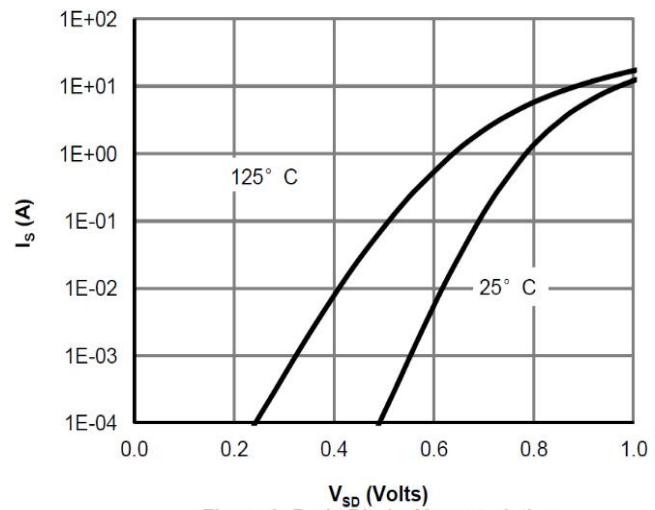

Figure 6: Body-Diode Characteristics

Electrical Characteristic Curve

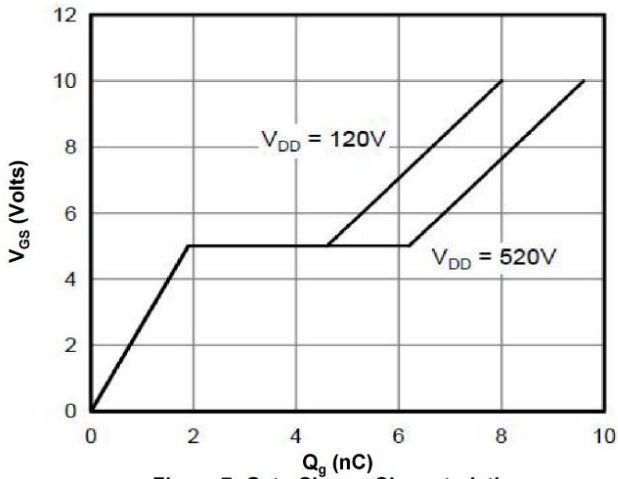

Figure 7: Gate-Charge Characteristics

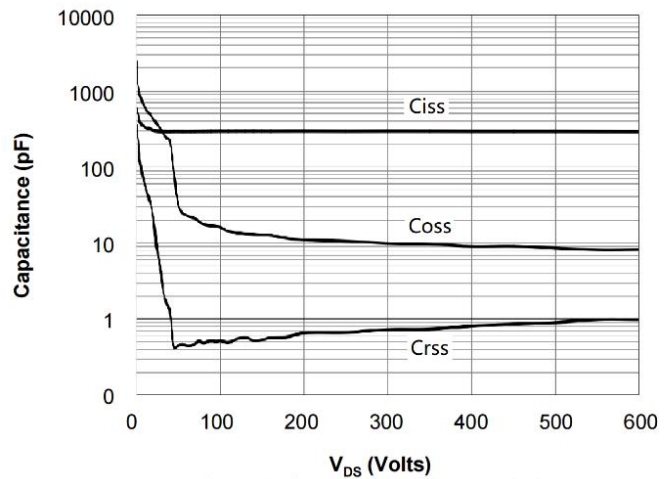

Figure 8: Capacitance Characteristics

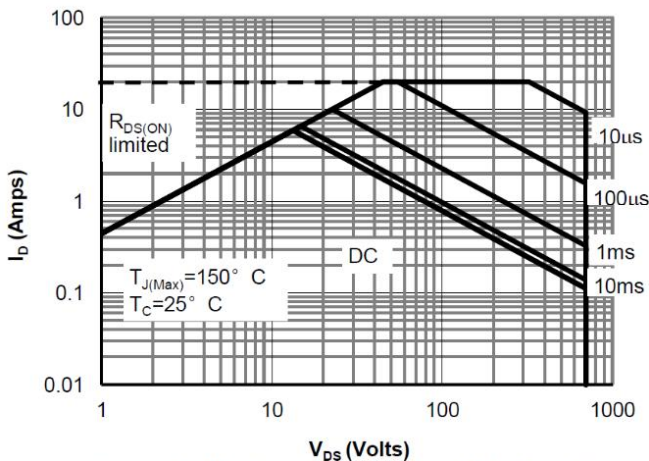

Figure 9 : Maximum Forward Biased Safe Operating Area

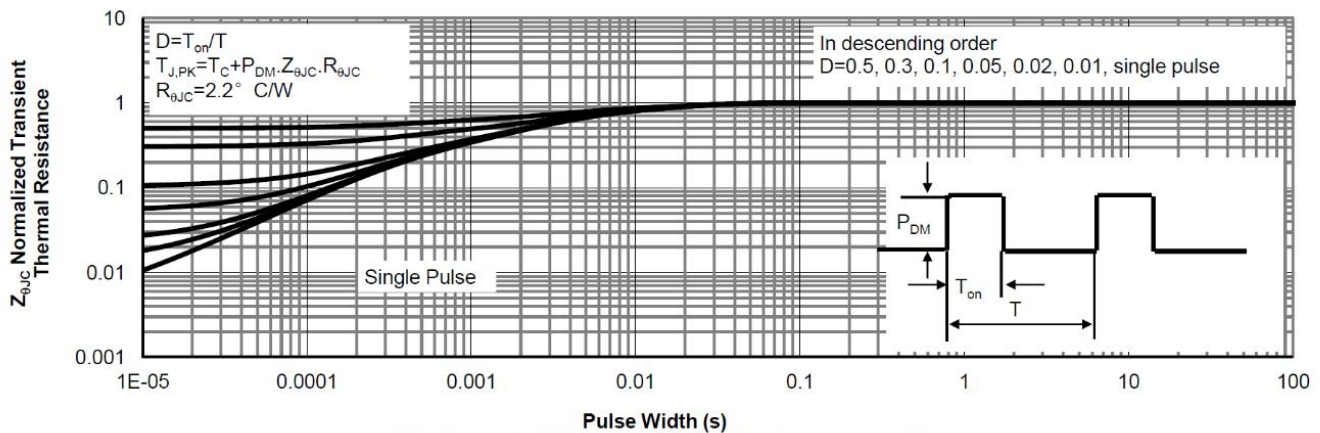

Figure 10: Normalized Maximum Transient Thermal Impedance

Marking Instructions



Note:

- COT: Company Code
- 65R1K0C: Product Type Code
- ****: Lot No. Code, code change with Lot No.

Packaging SPEC.

REEL

Package Type	Units					Dimension (unit: mm ³)		
	Units/Reel	Reels/Inner Box	Units/Inner Box	Inner Boxes/Outer Box	Units/Outer Box	Reel	Inner Box	Outer Box
TO-252	2,500	2	5,000	6	30,000	13" ×16	360×360×50	380×335×366

TUBE

Package Type	Units					Dimension (unit: mm ³)		
	Units/Tube	Tubes/Inner Box	Units/Inner Box	Inner Boxes/Outer Box	Units/Outer Box	Tube	Inner Box	Outer Box
TO-251/252	75	48	3,600	5	18,000	526×20.5×5.25	555×164×50	575×290×180

Package Dimensions

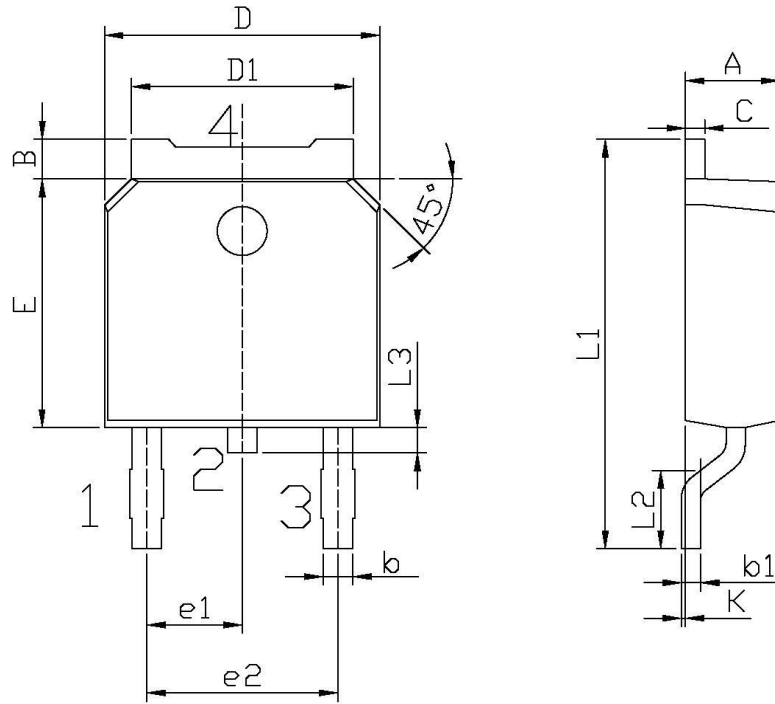

单位: mm

Symbol	Dimensions In Millimeters		Symbol	Dimensions In Millimeters	
	Min	Max		Min	Max
A	2.20	2.40	E	5.95	6.25
B	0.95	1.25	e1	2.24	2.34
b	0.70	0.90	e2	4.43	4.73
b1	0.45	0.55	L1	9.85	10.35
C	0.45	0.55	L2	1.70	2.00
D	6.45	6.75	L3	0.60	0.90
D1	5.10	5.50	K	0.00	0.10

TO-252